

25W

INDUCTION SPEED CONTROL MOTOR

□ 80mm LEAD WIRE TYPE

SPECIFICATION OF SR TYPE SPEED CONTROL MOTORS

SIZE mm sq.	Motor Type	Controller Type	Poles	Output (W)	Voltage (V)	Freq. (Hz)	Duty	Speed Range (rpm)	Permissible Torque				Starting Torque		Cap. (μ F)
									at 1200rpm		at 90rpm		(kg-cm)	(N-m)	
80	S8I25GA-S12 S8I25GA-S12(TP) S8I25GA-S12CE	SRA02 SRA02CE	4	25	1 \emptyset 110	60	Cont.	90-1700	1.70	0.170	0.80	0.080	1.50	0.150	6.0
	S8I25GB-S12 S8I25GB-S12(TP) S8I25GB-S12CE	SRB02 SRB02CE	4	25	1 \emptyset 220	60	Cont.	90-1700	1.70	0.170	0.80	0.080	1.50	0.150	1.5
	S8I25GC-S12 S8I25GC-S12(TP) S8I25GC-S12CE	SRC02 SRC02CE	4	25	1 \emptyset 100	50 60	Cont.	90-1400 90-1700	1.60 1.50	0.160 0.150	0.55	0.055	1.10	0.110	6.0
	S8I25GD-S12 S8I25GD-S12(TP) S8I25GD-S12CE	SRD02 SRD02CE	4	25	1 \emptyset 200	50 60	Cont.	90-1400 90-1700	1.60 1.50	0.160 0.150	0.55	0.055	1.10	0.110	1.5
	S8I25GX-S12 S8I25GX-S12CE	SRX02 SRX02CE	4	25	1 \emptyset 220 1 \emptyset 240	50	Cont.	90-1400	1.50 1.80	0.150 0.180	0.50 0.50	0.050 0.050	1.00 1.20	0.100 0.120	1.5

- ❖ CE marked at the end of motor model name indicates that it is thermally protected type which has received CE.
- ❖ SR type controller model with "CE" appeared at the end of motor model name indicates that the product acquired CE MARK certification.
- ❖ TP marked at the end of the motor model name indicates that it is standard motor with Thermal Protector mounted.
S8I25GX-S12, S8I25GX-S12CE is thermally protected type with TP mounted.
- ❖ "L" or "H" type does not apply to motors under 40W.

SPECIFICATION OF SS TYPE SPEED CONTROL MOTORS

SIZE mm sq.	Motor Type	Controller Type	Poles	Output (W)	Voltage (V)	Freq. (Hz)	Duty	Speed Range (rpm)	Permissible Torque				Starting Torque		Cap. (μ F)
									at 1200rpm		at 90rpm		(kg-cm)	(N-m)	
80	S8I25GA-S24 S8I25GA-S24(TP) S8I25GA-S24CE	SSA02-SRSS SSA03-SRSS	4	25	1 \emptyset 110	60	Cont.	90-1700	1.70	0.170	0.80	0.080	1.50	0.150	6.0
	S8I25GB-S24 S8I25GB-S24(TP) S8I25GB-S24CE	SSB02-SRSS SSB03-SRSS	4	25	1 \emptyset 220	60	Cont.	90-1700	1.70	0.170	0.80	0.080	1.50	0.150	1.5
	S8I25GC-S24 S8I25GC-S24(TP) S8I25GC-S24CE	SSC02-SRSS SSC03-SRSS	4	25	1 \emptyset 100	50 60	Cont.	90-1400 90-1700	1.60 1.50	0.160 0.150	0.55	0.055	1.10	0.110	6.0
	S8I25GD-S24 S8I25GD-S24(TP) S8I25GD-S24CE	SSD02-SRSS SSD03-SRSS	4	25	1 \emptyset 200	50 60	Cont.	90-1400 90-1700	1.60 1.50	0.160 0.150	0.55	0.055	1.10	0.110	1.5
	S8I25GX-S24 S8I25GX-S24CE	SSX02-SRSS SSX03-SRSS	4	25	1 \emptyset 220 1 \emptyset 240	50	Cont.	90-1400	1.50 1.80	0.150 0.180	0.50 0.50	0.050 0.050	1.00 1.20	0.100 0.120	1.5

- ❖ CE marked at the end of motor model name indicates that it is thermally protected type which has received CE.
- ❖ TP marked at the end of the motor model name indicates that it is standard motor with Thermal Protector mounted.
S8I25GX-S24, S8I25GX-S24CE is thermally protected type with TP mounted.
- ❖ "L" or "H" type does not apply to motors under 40W.

50Hz

GEAR RATIO		3	3.6	5	6	7.5	9	10	12.5	15	18	20	25	30	36	40	50	60	75	90	100	120	150	180	200
MODEL	rpm	500	416	300	250	200	166	150	120	100	83	75	60	50	41	37	30	25	20	16	15	12	10	8	7.5
	kg-cm	5.3	6.4	8.9	10.7	13.4	16.0	17.8	22.3	26.7	32.1	32.1	40.2	48.2	57.8	64.2	72.6	80.0	80.0	80.0	80.0	80.0	80.0	80.0	80.0
S8KA□B	N·m	0.519	0.627	0.872	1.049	1.313	1.568	1.744	2.185	2.617	3.146	3.146	3.940	4.724	5.664	6.292	7.115	7.840	7.840	7.840	7.840	7.840	7.840	7.840	7.840

60Hz

GEAR RATIO		3	3.6	5	6	7.5	9	10	12.5	15	18	20	25	30	36	40	50	60	75	90	100	120	150	180	200
MODEL	rpm	600	500	360	300	240	200	180	144	120	100	90	72	60	50	45	36	30	24	20	18	15	12	10	9
	kg-cm	4.4	5.2	7.3	8.7	10.9	13.1	14.6	18.2	21.9	26.2	26.3	32.9	39.4	47.3	52.6	59.4	71.3	80.0	80.0	80.0	80.0	80.0	80.0	80.0
S8KA□B	N·m	0.431	0.510	0.715	0.853	1.068	1.284	1.431	1.784	2.146	2.568	2.577	3.224	3.861	4.635	5.155	5.821	6.987	7.840	7.840	7.840	7.840	7.840	7.840	7.840

- ❖ The code in □ of gearhead model is for gear ratio.
- ❖ It is the permissible torque of the assembled motor and gearhead.
- ❖ The permissible torque of the motor and inter-decimal gearhead is 80 kg-cm.
- ❖ ■ color indicates that the output shaft of the geared motor rotates in the same direction as the output shaft of the motor.
Others indicate rotation in the opposite direction.
- ❖ Rpm is based on synchronous speed (50Hz: 1500rpm, 60Hz: 1800rpm) divided by gear ratio.
The actual rotation speed can be 2~20% less than displayed value depending on the load.
- ❖ "L" or "H" type does not apply to motors under 40W.

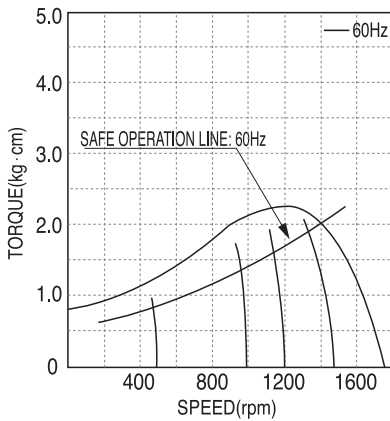

- ▲ S8I25GA-S12 S8I25GA-S24
- S8I25GA-S12(TP) S8I25GA-S24(TP)
- S8I25GA-S12CE S8I25GA-S24CE
- S8I25GB-S12 S8I25GB-S24
- S8I25GB-S12(TP) S8I25GB-S24(TP)
- S8I25GB-S12CE S8I25GB-S24

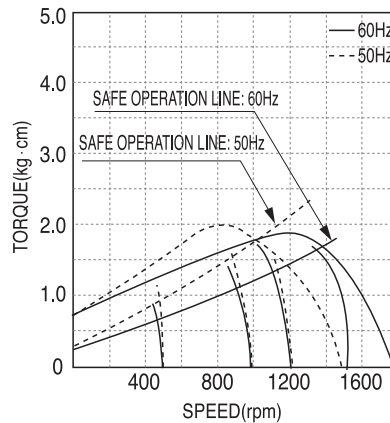

- ▲ S8I25GC-S12 S8I25GC-S24
- S8I25GC-S12(TP) S8I25GC-S24(TP)
- S8I25GC-S12CE S8I25GC-S24CE
- S8I25GD-S12 S8I25GD-S24
- S8I25GD-S12(TP) S8I25GD-S24(TP)
- S8I25GD-S12CE S8I25GD-S24

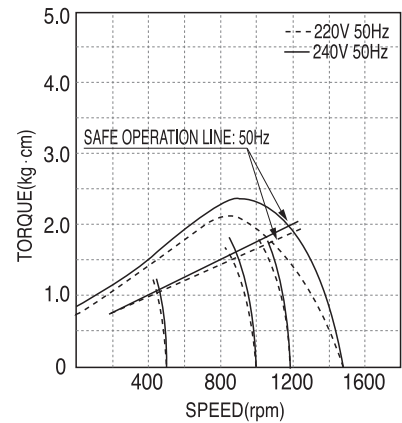

- ▲ S8I25GX-S12 S8I25GX-S24
- S8I25GX-S12CE S8I25GX-S24CE

DIMENSIONS

+ GEARED MOTOR

※ MOTOR MODEL : S8I(15,25)G□-S12, S8I(15,25)G□-S24
 ※ HEAD MODEL : S8□A3□~S8□A200□

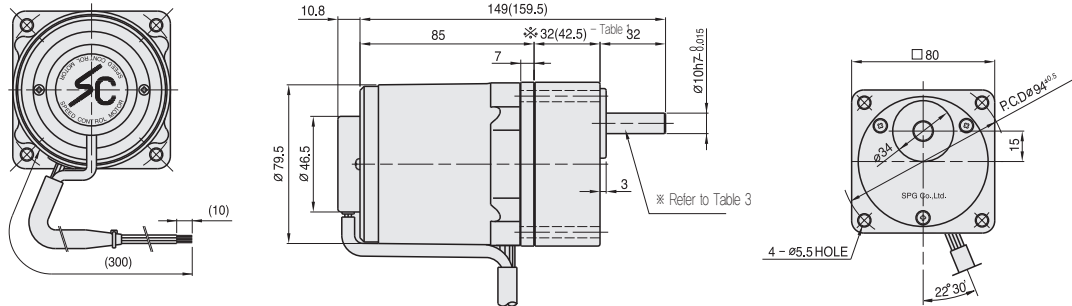

+ MOTOR

※ MOTOR MODEL : S8I(15,25)□□-S12, S8I(15,25)□□-S24

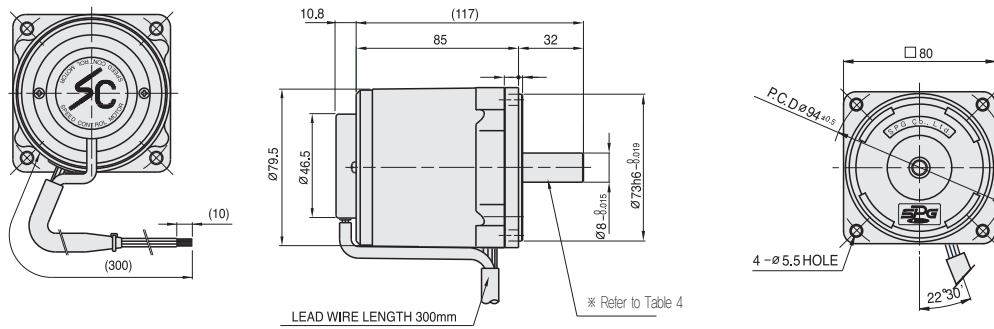

+ INTER-DECIMAL GEAR HEAD

※ MODEL : S8GX10B

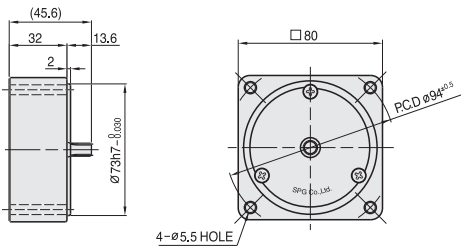

+ KEY SPEC

GEAR HEAD	MOTOR

+ ※26(35) - (Table 1)

GEAR RATIO	SIZE(mm)
S8□A3□ ~ S8□A18□	32
S8□A20□ ~ S8□A200□	42.5

+ WEIGHT - (Table 2)

PART	WEIGHT(kg)	
15W MOTOR	1.6	
25W MOTOR	1.6	
DECIMAL GEAR HEAD	0.43	
GEAR HEAD	S8□A3□ ~ S8□A18□	0.43
	S8□A20□ ~ S8□A40□	0.57
	S8□A50□ ~ S8□A200□	0.61

+ SPEC for output shaft of gearhead - (Table 3)

MODEL	TYPES OF OUTPUT SHAFT
S8SA3□ ~S8SA200□	STRAIGHT TYPE
	D-CUT TYPE
S8DA3□ ~S8DA200□	KEY TYPE
	KEY TYPE

+ SPEC for output shaft of motor - (Table 4)

MODEL	TYPES OF OUTPUT SHAFT
S8I15G□-S12 S8I25G□-S12 S8I15G□-S24 S8I25G□-S24	GEAR TYPE
	STRAIGHT TYPE
	D-CUT TYPE
	KEY TYPE
S8I15S□-S12 S8I25S□-S12 S8I15S□-S24 S8I25S□-S24	STRAIGHT TYPE
	D-CUT TYPE
	KEY TYPE
	KEY TYPE