

Powermec

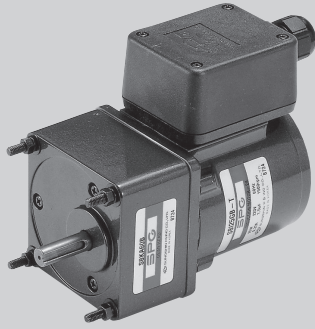

25W

INDUCTION MOTOR, REVERSIBLE MOTOR

□ 80mm TERMINAL BOX TYPE

INDUCTION MOTOR - CONTINUOUS RATING

SIZE mm sq.	Type	Poles	Output (W)	Voltage (V)	Frequency (Hz)	Duty	Rated Load				Starting Torque		Capacitor (uF)
							Current (A)	Speed (rpm)	Torque (kg-cm) (N-m)		(kg-cm)	(N-m)	
80	S8I25GA-T S8I25GA-T1	4	25	1 Ø 110	60	Cont.	0.51	1600	1.60	0.160	1.80	0.180	6.0
	S8I25GB-T S8I25GB-T1	4	25	1 Ø 220	60	Cont.	0.23	1550	1.65	0.165	1.80	0.180	1.5
	S8I25GC-T S8I25GC-T1	4	25	1 Ø 100	50 60	Cont.	0.57 0.52	1250 1550	2.00 1.65	0.200 0.165	1.45	0.145	6.0
	S8I25GD-T S8I25GD-T1	4	25	1 Ø 200	50 60	Cont.	0.30 0.29	1250 1500	2.00 1.70	0.200 0.170	1.45	0.145	1.5
	S8I25GX-T S8I25GX-T1 S8I25GX-TCE S8I25GX-T1CE	4	25	1 Ø 220 1 Ø 240	50	Cont.	0.23 0.25	1200	2.10 2.20	0.210 0.220	1.10 1.30	0.110 0.180	1.3
	S8I25GU-T S8I25GU-T1 S8I25GU-TCE S8I25GU-T1CE	4	25	3 Ø 200	50 60	Cont.	0.26 0.24	1300 1550	1.95 1.65	0.195 0.165	3.50 2.90	0.350 0.290	-
	S8I25GT-T S8I25GT-T1 S8I25GT-TCE S8I25GT-T1CE	4	25	3 Ø 220	50 60	Cont.	0.28 0.24	1350 1600	1.90 1.60	0.190 0.160	4.20 3.50	0.420 0.350	-
	S8I25GS-T S8I25GS-T1 S8I25GS-TCE S8I25GS-T1CE	4	25	3 Ø 380 3 Ø 400 3 Ø 415 3 Ø 440	50 60 50 60 50 60	Cont. Cont. Cont. Cont.	0.14 0.12 0.14 0.12 0.15 0.13 0.15 0.13	1250 1500 1250 1500 1300 1550 1300 1550	2.00 1.70 2.10 1.80 1.95 1.65 2.10 1.80	0.200 0.170 0.210 0.180 0.195 0.165 0.210 0.180	3.15 2.50 3.50 2.75 3.75 3.00 4.40 3.40	0.315 0.250 0.350 0.275 0.375 0.300 0.440 0.340	-

❖ CE marked at the end of the model name indicates that it is thermally protected type which has received CE with built-in TP.

❖ TP marked at the end of the model name indicates that it is standard motor with Thermal Protector mounted.

S8I25GX-T, S8I25GS-T is thermally protected type with TP mounted.

❖ "L" or "H" type does not apply to motors under 40W.

❖ For a three-phase 380V~440V motor, be cautious when using the inverter. When inverter is used, the insulation of winding becomes hot and may cause damage to motor.

REVERSIBLE MOTOR - 30MINUTES RATING

SIZE mm sq.	Type	Poles	Output (W)	Voltage (V)	Frequency (Hz)	Duty	Rated Load				Starting Torque		Capacitor (uF)
							Current (A)	Speed (rpm)	Torque (kg-cm) (N-m)		(kg-cm)	(N-m)	
80	S8R25GA-T S8R25GA-T S8R25GA-T(TP) S8R25GA-T1(TP) S8R25GA-TCE S8R25GA-T1CE	4	25	1 ∅ 110	60	30min.	0.71	1550	1.70	0.170	2.30	0.230	10.0
	S8R25GB-T S8R25GB-T S8R25GB-T(TP) S8R25GB-T1(TP) S8R25GB-TCE S8R25GB-T1CE	4	25	1 ∅ 220	60	30min.	0.35	1600	1.65	0.165	2.30	0.230	2.5
	S8R25GC-T S8R25GC-T S8R25GC-T(TP) S8R25GC-T1(TP) S8R25GC-TCE S8R25GC-T1CE	4	25	1 ∅ 100	50 60	30min.	0.63 0.70	1250 1500	2.10 1.70	0.210 0.170	1.80	0.180	10.0
	S8R25GD-T S8R25GD-T S8R25GD-T(TP) S8R25GD-T1(TP) S8R25GD-TCE S8R25GD-T1CE	4	25	1 ∅ 200	50 60	30min.	0.33	1250 1550	2.10 1.70	0.210 0.170	1.80	0.180	2.5
	S8R25GE-T S8R25GE-T S8R25GE-T(TP) S8R25GE-T1(TP) S8R25GE-TCE S8R25GE-T1CE	4	25	1 ∅ 100 1 ∅ 115	50 60 60	30min.	0.60 0.65 0.63	1250 1450 1550	2.10 1.80 1.70	0.210 0.180 0.170	1.30	0.130	8.0 7.0
	S8R25GX-T S8R25GX-T S8R25GX-TCE S8R25GX-T1CE	4	25	1 ∅ 220 1 ∅ 240	50	30min.	0.26 0.28	1200	2.00 2.20	0.200 0.220	1.70	0.170	2.0

- ❖ Appropriate capacitors shall be used according to the voltage for S8R25GE-T type since the size of the capacitor differs by different voltages. Malfunction may occur when not used properly. Capacitor for 115V will be delivered otherwise the required voltage is informed.
- ❖ CE marked at the end of the model name indicates that it is thermally protected type which has received CE. S8R25GE-TCE is available only for 115V specification.
- ❖ TP marked at the end of the model name indicates that it is standard motor with Thermal Protector mounted.
S8R25GE-T, S8R25GX-T is thermally protected type with TP mounted.
- ❖ Above data is measured with friction brake mounted.
- ❖ "L" or "H" type does not apply to motors under 40W.

50Hz

GEAR RATIO	3	3.6	5	6	7.5	9	10	12.5	15	18	20	25	30	36	40	50	60	75	90	100	120	150	180	200	
	MODEL	rpm	500	416	300	250	200	166	150	120	100	83	75	60	50	41	37	30	25	20	16	15	12	10	8
S8KA□B	kg-cm	5.3	6.4	8.9	10.7	13.4	16.0	17.8	22.3	26.7	32.1	32.1	40.2	48.2	57.8	64.2	72.6	80.0	80.0	80.0	80.0	80.0	80.0	80.0	80.0
	Nm	0.519	0.627	0.872	1.049	1.313	1.568	1.744	2.185	2.617	3.146	3.146	3.940	4.724	5.664	6.292	7.115	7.840	7.840	7.840	7.840	7.840	7.840	7.840	7.840

60Hz

GEAR RATIO	3	3.6	5	6	7.5	9	10	12.5	15	18	20	25	30	36	40	50	60	75	90	100	120	150	180	200	
	MODEL	rpm	600	500	360	300	240	200	180	144	120	100	90	72	60	50	45	36	30	24	20	18	15	12	10
S8KA□B	kg-cm	4.4	5.2	7.3	8.7	10.9	13.1	14.6	18.2	21.9	26.2	26.3	32.9	39.4	47.3	52.6	59.4	71.3	80.0	80.0	80.0	80.0	80.0	80.0	80.0
	Nm	0.431	0.510	0.715	0.853	1.068	1.284	1.431	1.784	2.146	2.568	2.577	3.224	3.861	4.635	5.155	5.821	6.987	7.840	7.840	7.840	7.840	7.840	7.840	7.840

- ❖ The code in □ of gearhead model is for gear ratio.
- ❖ It is the permissible torque of the assembled motor and gearhead.
- ❖ The permissible torque of the motor and inter-decimal gearhead is 8 kg-cm.
- ❖ ■ color indicates that the output shaft of the geared motor rotates in the same direction as the output shaft of the motor.
Others indicate rotation in the opposite direction.
- ❖ Rpm is based on synchronous speed (50Hz: 1500rpm, 60Hz: 1800rpm) divided by gear ratio.
The actual rotation speed can be 2~20% less than displayed value depending on the load.
- ❖ "L" or "H" type does not apply to motors under 40W.

DIMENSIONS

+ GEARED MOTOR

* MOTOR MODEL : S8(I,R)25G□-T
* HEAD MODEL : S8□A3□~S8□A200□

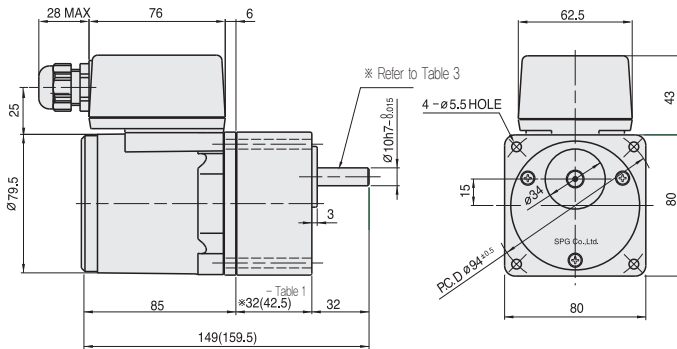

+ INTER-DECIMAL GEAR HEAD

* MODEL : S8GX10B

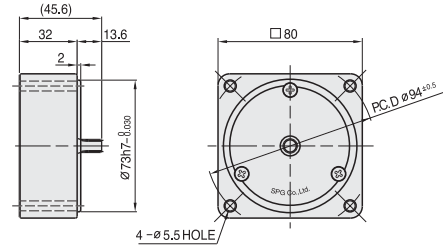

+ MOTOR

* MOTOR MODEL : S8(I,R)25□□-T

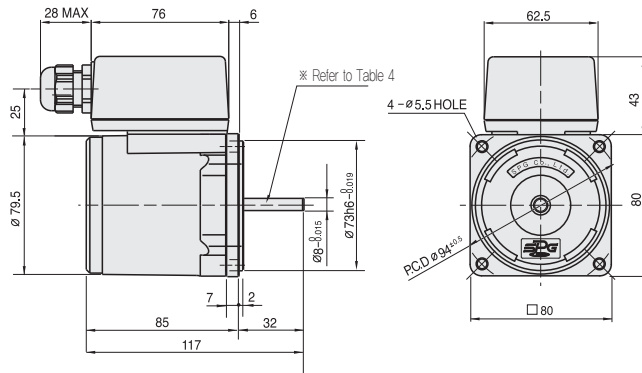

+ WEIGHT - (Table 2)

PART		WEIGHT(kg)
MOTOR		1.60
REVERSIBLE MOTOR		1.65
DECIMAL GEAR HEAD		0.43
GEAR HEAD	S8□A3□ ~S8□A18□	0.43
	S8□A20□ ~S8□A40□	0.57
	S8□A50□ ~S8□A200□	0.61

+ GEARED MOTOR

* MOTOR MODEL : S8(I,R)25G□-T1
* HEAD MODEL : S8□A3□~S8□A200□

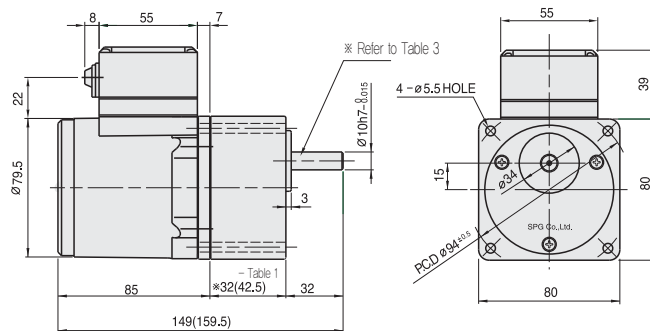

+ INTER-DECIMAL GEAR HEAD

* MODEL : S8GX10B

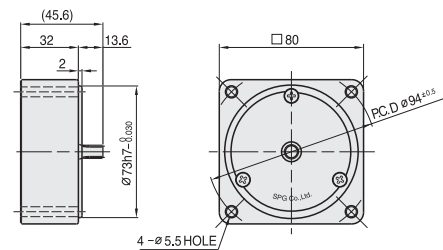

+ MOTOR

* MOTOR MODEL : S8(I,R)25□□-T1

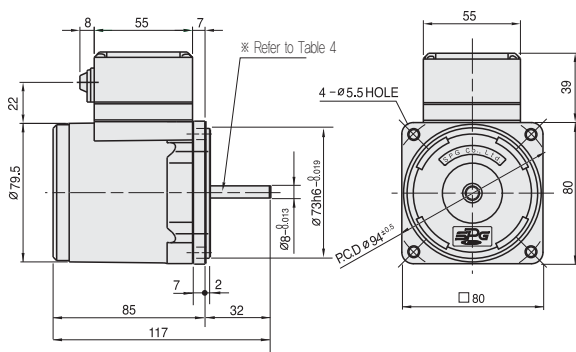

+ WEIGHT - (Table 2)

PART		WEIGHT(kg)
MOTOR		1.55
REVERSIBLE MOTOR		1.60
DECIMAL GEAR HEAD		0.43
GEAR HEAD	S8□A3□ ~S8□A18□	0.43
	S8□A20□ ~S8□A40□	0.57
	S8□A50□ ~S8□A200□	0.61

DIMENSIONS

※26(35) - (Table 1)

GEAR RATIO	SIZE(mm)
S8□A3□ ~ S8□A18□	32
S8□A20□ ~ S8□A200□	42.5

KEY SPEC

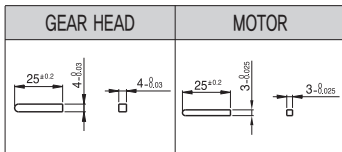

SPEC for output shaft of gearhead - (Table 3)

MODEL	TYPES OF OUTPUT SHAFT
STRAIGHT TYPE	
S8SA3□ ~S8SA200□	
D-CUT TYPE	
S8DA3□ ~S8DA200□	
KEY TYPE	
S8KA3□ ~S8KA200□	

SPEC for output shaft of motor - (Table 4)

MODEL	TYPES OF OUTPUT SHAFT
GEAR TYPE	
S8(I,R)25G□-T S8(I,R)25G□-T1	
STRAIGHT TYPE	
S8(I,R)25S□-T S8(I,R)25S□-T1	
D-CUT TYPE	
S8(I,R)25D□-T S8(I,R)25D□-T1	
KEY TYPE	
S8(I,R)25K□-T S8(I,R)25K□-T1	

SCHEMATIC DIAGRAMS

The direction of motor rotation is as viewed from the front shaft end of the motor.
Circled number is the terminal number inside terminal box.

INDUCTION MOTOR

S8I25GA-T S8I25GB-T S8I25GC-T S8I25GD-T S8I25GA-T1 S8I25GB-T1 S8I25GC-T1 S8I25GD-T1	S8I25GX-T S8I25GX-TCE S8I25GX-T1 S8I25GX-T1CE	S8I25GU-T S8I25GT-T S8I25GU-T1 S8I25GT-T1	S8I25GU-TCE S8I25GU-T1CE	S8I25GT-TCE S8I25GT-T1CE
CW	CCW	CW,CCW	CW	CCW

REVERSIBLE MOTOR

S8R25GS-TCE S8I25GS-T S8I25GS-T1CE S8I25GS-T1	S8R25GA-T, S8R25GB-T S8R25GA-T1, S8R25GB-T1 S8R25GC-T, S8R25GD-T S8R25GC-T1, S8R25GD-T1	S8R25GX-T, S8R25GX-TCE S8R25GX-T1, S8R25GX-T1CE	S8R25GA-T(TP), S8R25GB-T(TP), S8R25GC-T(TP), S8R25GD-T(TP), S8R25GA-T1(TP), S8R25GB-T1(TP), S8R25GC-T1(TP), S8R25GD-T1(TP), S8R25GA-TCE, S8R25GB-TCE, S8R25GC-TCE S8R25GD-TCE, S8R25GE-T, S8R25GE-TCE S8R25GA-T1CE, S8R25GB-T1CE, S8R25GC-T1CE S8R25GD-T1CE, S8R25GE-T1, S8R25GE-T1CE	
CW	CCW	CW,CCW	CW,CCW	CW,CCW

Change the direction of motor rotation only after the motor stops completely. If an attempt is made to change the direction of rotation while the motor is running, the motor may ignore the reversing command or change its direction of rotation after some delay.