

## 90W

INDUCTION SPEED CONTROL MOTOR

□ 90mm LEAD WIRE TYPE

### SPECIFICATION OF SR TYPE SPEED CONTROL MOTORS

SIZE mm sq.	Motor Type	Controller Type	Poles	Output (W)	Voltage (V)	Freq. (Hz)	Duty	Speed Range (rpm)	Permissible Torque				Starting Torque		Cap. (μF)
									at 1200rpm		at 90rpm		(kg-cm)	(N-m)	
90	S9I90GA()-S12 S9I90GA()-S12(TP) S9I90GA()-S12CE	SRA02 SRA02CE	4	90	1 ∅ 110	60	Cont.	90-1700	6.30	0.630	3.00	0.300	6.50	0.650	24.0
	S9I90GB()-S12 S9I90GB()-S12(TP) S9I90GB()-S12CE	SRB02 SRB02CE	4	90	1 ∅ 220	60	Cont.	90-1700	6.30	0.630	3.00	0.300	6.50	0.650	7.0
	S9I90GC()-S12 S9I90GC()-S12(TP) S9I90GC()-S12CE	SRC02 SRC02CE	4	90	1 ∅ 100	50 60	Cont.	90-1400 90-1700	5.80 5.30	0.580 0.530	2.50	0.250	5.50	0.550	24.0
	S9I90GD()-S12 S9I90GD()-S12(TP) S9I90GD()-S12CE	SRD02 SRD02CE	4	90	1 ∅ 200	50 60	Cont.	90-1400 90-1700	5.80 5.30	0.580 0.530	2.50	0.250	5.50	0.550	7.0
	S9I90GX()-S12 S9I90GX()-S12CE	SRX02 SRX02CE	4	90	1 ∅ 220 1 ∅ 240	50	Cont.	90-1400	5.40 6.10	0.540 0.610	2.20 2.20	0.220 0.220	4.60 5.50	0.460 0.550	5.0

- ❖ CE marked at the end of motor model name indicates that it is thermally protected type which has received CE.
- ❖ SR type controller model with "CE" appeared at the end of motor model name indicates that the product acquired CE MARK certification.
- ❖ TP marked at the end of the motor model name indicates that it is standard motor with Thermal Protector mounted.  
S9I90GX() -S24, S9I90GX() -S24CE is thermally protected type with TP mounted.
- ❖ () is for marking 'L' type or 'H'. 'L' should be used with gearhead 'L' and 'H' should be used with gearhead 'H'.

### SPECIFICATION OF SS TYPE SPEED CONTROL MOTORS

SIZE mm sq.	Motor Type	Controller Type	Poles	Output (W)	Voltage (V)	Freq. (Hz)	Duty	Speed Range (rpm)	Permissible Torque				Starting Torque		Cap. (μF)
									at 1200rpm		at 90rpm		(kg-cm)	(N-m)	
90	S9I90GA()-S24 S9I90GA()-S24(TP) S9I90GA()-S24CE	SSA03-SRSS	4	90	1 ∅ 110	60	Cont.	90-1700	6.30	0.630	3.00	0.300	6.50	0.650	24.0
	S9I90GB()-S24 S9I90GB()-S24(TP) S9I90GB()-S24CE	SSB03-SRSS	4	90	1 ∅ 220	60	Cont.	90-1700	6.30	0.630	3.00	0.300	6.50	0.650	7.0
	S9I90GC()-S24 S9I90GC()-S24(TP) S9I90GC()-S24CE	SSC03-SRSS	4	90	1 ∅ 100	50 60	Cont.	90-1400 90-1700	5.80 5.30	0.580 0.530	2.50	0.250	5.50	0.550	24.0
	S9I90GD()-S24 S9I90GD()-S24(TP) S9I90GD()-S24CE	SSD03-SRSS	4	90	1 ∅ 200	50 60	Cont.	90-1400 90-1700	5.80 5.30	0.580 0.530	2.50	0.250	5.50	0.550	7.0
	S9I90GX()-S24 S9I90GX()-S24CE	SSX03-SRSS	4	90	1 ∅ 220 1 ∅ 240	50	Cont.	90-1400	5.40 6.10	0.540 0.610	2.20 2.20	0.220 0.220	4.60 5.50	0.460 0.550	5.0

- ❖ CE marked at the end of motor model name indicates that it is thermally protected type which has received CE.
- ❖ TP marked at the end of the motor model name indicates that it is standard motor with Thermal Protector mounted.  
S9I90GX() -S24, S9I90GX() -S24CE is thermally protected type with TP mounted.
- ❖ () is for marking 'L' type or 'H'. 'L' should be used with gearhead 'L' and 'H' should be used with gearhead 'H'.

## 50Hz

GEAR RATIO		3	3.6	5	6	7.5	9	10	12.5	15	18	20	25	30	36	40	50	60	75	90	100	120	150	180	200
MODEL	rpm	500	416	300	250	200	166	150	120	100	83	75	60	50	41	37	30	25	20	16	15	12	10	8	7.5
	kg·cm	18.2	21.9	30.4	36.5	45.6	54.7	60.8	68.4	82.1	98.6	110	124	149	178	198	200	200	200	200	200	200	200	200	200
S9KC□B( )	kg·cm	18.2	21.9	30.4	36.5	45.6	54.7	60.8	68.4	82.1	98.6	110	124	149	178	198	200	200	200	200	200	200	200	200	200
S9KC□B( )-S	N·m	1.784	2.146	2.979	3.577	4.469	5.361	5.958	6.703	8.046	9.663	10.78	12.15	14.60	17.44	19.40	19.60	19.60	19.60	19.60	19.60	19.60	19.60	19.60	19.60

## 60Hz

GEAR RATIO		3	3.6	5	6	7.5	9	10	12.5	15	18	20	25	30	36	40	50	60	75	90	100	120	150	180	200
MODEL	rpm	600	500	360	300	240	200	180	144	120	100	90	72	60	50	45	36	30	24	20	18	15	12	10	9
	kg·cm	14.6	17.5	24.3	29.2	36.5	43.7	48.6	54.8	65.7	78.8	87.6	99.0	119	143	158	198	200	200	200	200	200	200	200	200
S9KC□B( )	kg·cm	14.6	17.5	24.3	29.2	36.5	43.7	48.6	54.8	65.7	78.8	87.6	99.0	119	143	158	198	200	200	200	200	200	200	200	200
S9KC□B( )-S	N·m	1.431	1.715	2.381	2.862	3.577	4.675	4.763	5.370	6.439	7.722	8.585	9.702	11.66	14.01	15.48	19.40	19.60	19.60	19.60	19.60	19.60	19.60	19.60	19.60

- ❖ The code in □ of gearhead model is for gear ratio.
- ❖ It is the permissible torque of the assembled motor and gearhead.
- ❖ The permissible torque of the motor and inter-decimal gearhead is 200 kg·cm.
- ❖ ■ color indicates that the output shaft of the geared motor rotates in the same direction as the output shaft of the motor. Others indicate rotation in the opposite direction.
- ❖ Rpm is based on synchronous speed (50Hz: 1500rpm, 60Hz: 1800rpm) divided by gear ratio. The actual rotation speed can be 2~20% less than displayed value depending on the load.
- ❖ ( ) is for marking 'L' type or 'H'. 'L' should be used with motor 'L' and 'H' should be used with motor 'H'.

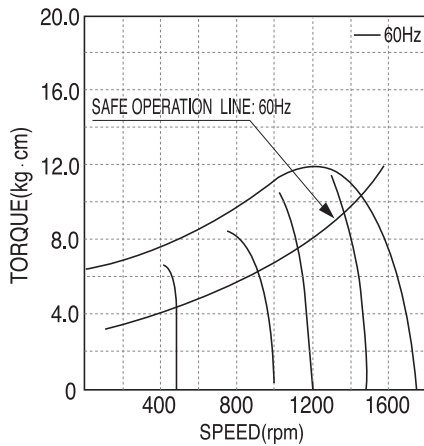

- ▲ S9I90GA()-S12      S9I90GA()-S24
- S9I90GA()-S12(TP)    S9I90GA()-S24(TP)
- S9I90GA()-S12CE    S9I90GA()-S24CE
- S9I90GB()-S12      S9I90GB()-S24
- S9I90GB()-S12(TP)    S9I90GB()-S24(TP)
- S9I90GB()-S12CE    S9I90GB()-S24

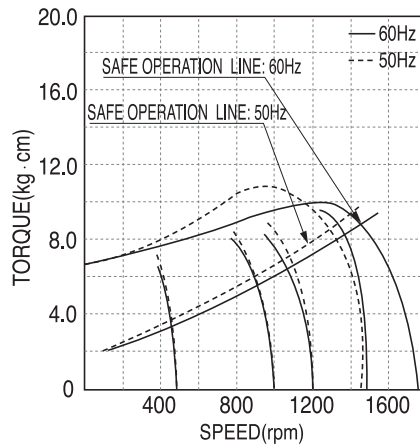

- ▲ S9I90GC()-S12      S9I90GC()-S24
- S9I90GC()-S12(TP)    S9I90GC()-S24(TP)
- S9I90GC()-S12CE    S9I90GC()-S24CE
- S9I90GD()-S12      S9I90GD()-S24
- S9I90GD()-S12(TP)    S9I90GD()-S24(TP)
- S9I90GD()-S12CE    S9I90GD()-S24

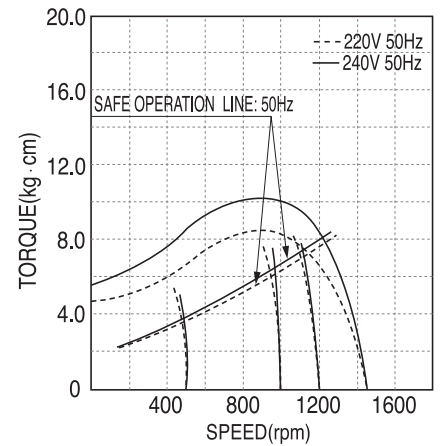

- ▲ S9I90GX()-S12      S9I90GX()-S24
- S9I90GX()-S12CE    S9I90GX()-S24CE

# DIMENSIONS

## + GEARED MOTOR

- \* MOTOR MODEL : S9I90G□□-S12, S9I90G□□-S24
- \* HEAD MODEL : S9□C3B□-S ~ S9□C200B□-S

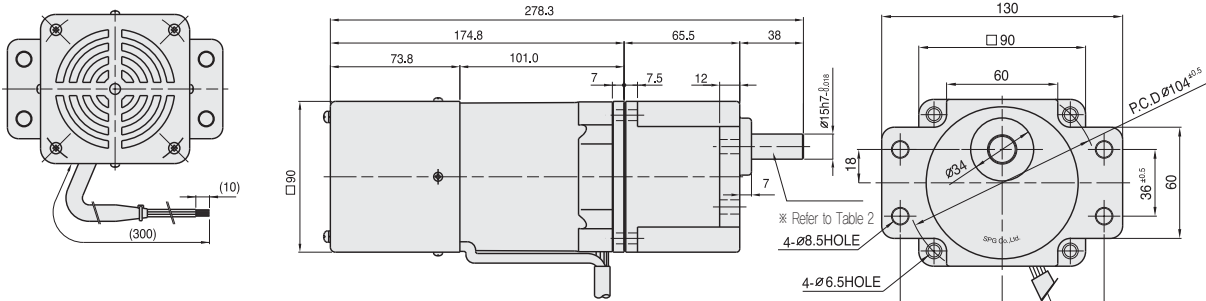

- \* HEAD MODEL : S9□C3B ~ S9□C200B□

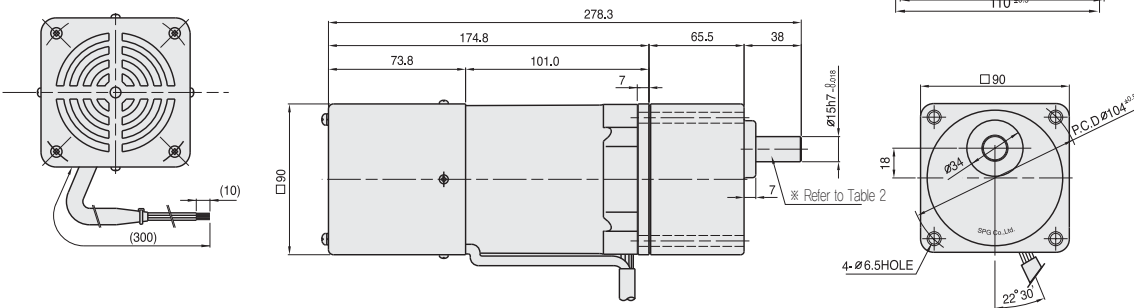

## + MOTOR

- \* MOTOR MODEL : S9I90□□□-S12, S9I90□□□-S24

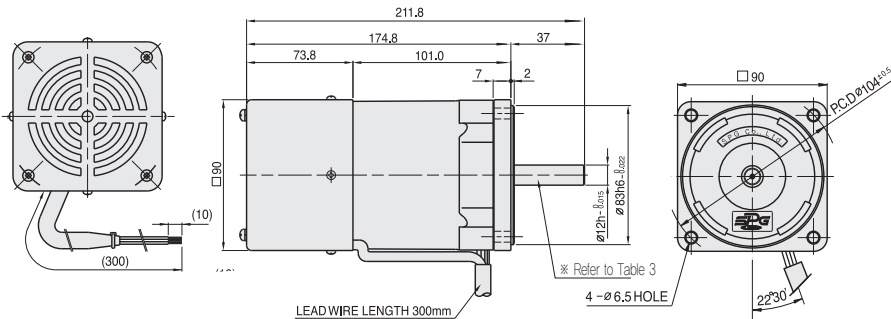

## + INTER-DECIMAL GEAR HEAD

- \* MODEL : S9GX10B(H,L)-S

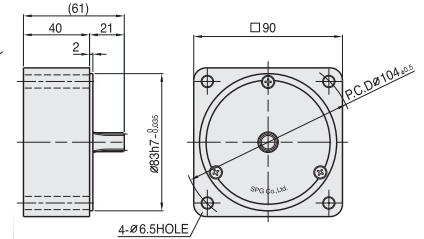

## + WEIGHT - (Table1)

PART	WEIGHT(kg)	
MOTOR	3.53	
DECIMAL GEAR HEAD	0.65	
GEAR HEAD	S9□C3B□ ~S9□C10B□	1.21
	S9□C12.5B□ ~S9□C20B□	1.30
	S9□C25B□ ~S9□C60B□	1.40
	S9□C75B□ ~S9□C200B□	1.45

## + KEY SPEC

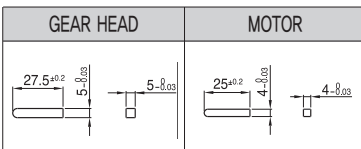

## + SPEC for output shaft of gearhead - (Table2)

MODEL	TYPES OF OUTPUT SHAFT
STRAIGHT TYPE	
	S9SC3B□ ~S9SC200B□
D-CUT TYPE	
	S9DC3B□ ~S9DC200B□
KEY TYPE	
	S9KC3B□ ~S9KC200B□

## + SPEC for output shaft of motor - (Table3)

MODEL	TYPES OF OUTPUT SHAFT
GEAR TYPE	
	S9I90G□□-S12 S9I90G□□-S24
STRAIGHT TYPE	
	S9I90S□-S12 S9I90S□-S24
D-CUT TYPE	
	S9I90D□-S12 S9I90D□-S24
KEY TYPE	
	S9I90K□-S12 S9I90K□-S24

# DIMENSIONS

## + GEARED MOTOR

- \* MOTOR MODEL : S9I90G□H-S12, S9I90G□H-S24
- \* HEAD MODEL : S9□D3B-S9□D200B

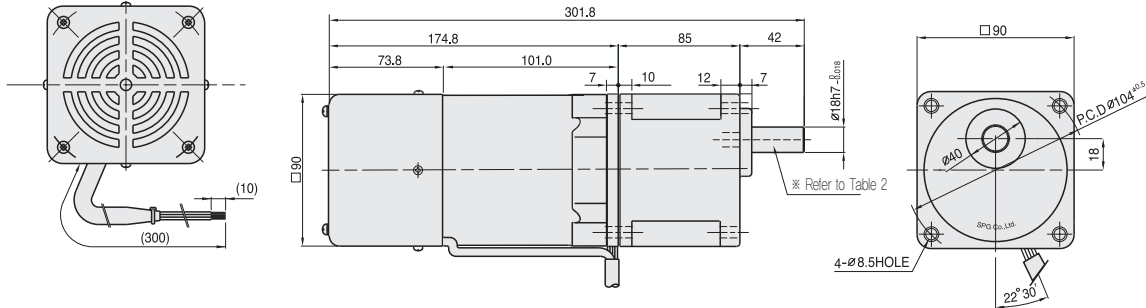

## + WEIGHT - (Table1)

PART		WEIGHT(kg)
MOTOR		3.53
GEAR HEAD	S9□D3B ~S9□D10B	1.65
	S9□D12.5B ~S9□D20B	1.80
	S9□D25B ~S9□D60B	1.90
	S9□D75B ~S9□D200B	1.95

## + SPEC for output shaft of gearhead - (Table2)

MODEL	TYPES OF OUTPUT SHAFT
STRAIGHT TYPE	
S9SD3B ~S9SD200B	
D-CUT TYPE	
S9DD3B ~S9DD200B	
KEY TYPE	
S9KD3B ~S9KD200B	

## + KEY SPEC

GEAR HEAD	

## 50Hz

MODEL	GEAR RATIO	3	3.6	5	6	7.5	9	10	12.5	15	18	20	25	30	36	40	50	60	75	90	100	120	150	180	200
	rpm	500	416	300	250	200	166	150	120	100	83	75	60	50	41	37	30	25	20	16	15	12	10	8	7.5
S9KD□B	kg-cm	18.2	21.9	30.4	36.5	45.6	54.7	60.8	68.4	82.1	98.6	110	124	149	178	198	248	297	300	300	300	300	300	300	300
	N·m	1.784	2.146	2.979	3.577	4.469	5.361	5.958	6.703	8.046	9.663	10.78	12.15	14.60	17.44	19.40	24.32	29.13	29.42	29.42	29.42	29.42	29.42	29.42	29.42

## 60Hz

MODEL	GEAR RATIO	3	3.6	5	6	7.5	9	10	12.5	15	18	20	25	30	36	40	50	60	75	90	100	120	150	180	200
	rpm	600	500	360	300	240	200	180	144	120	100	90	72	60	50	45	36	30	24	20	18	15	12	10	9
S9KD□B	kg-cm	14.6	17.5	24.3	29.2	36.5	43.7	48.6	54.8	65.7	78.8	87.6	99.0	119	143	158	198	238	266	300	300	300	300	300	300
	N·m	1.431	1.715	2.381	2.862	3.577	4.675	4.763	5.370	6.439	7.722	8.585	9.702	11.66	14.01	15.48	19.40	23.34	26.09	29.42	29.42	29.42	29.42	29.42	29.42

- ❖ The code in □ of gearhead model is for gear ratio.
- ❖ It is the permissible torque of the assembled motor and gearhead.
- ❖ The permissible torque of the motor and inter-decimal gearhead is 300 kg-cm.
- ❖ ■ color indicates that the output shaft of the geared motor rotates in the same direction as the output shaft of the motor. Others indicate rotation in the opposite direction.
- ❖ Rpm is based on synchronous speed (50Hz: 1500rpm, 60Hz: 1800rpm) divided by gear ratio. The actual rotation speed can be 2~20% less than displayed value depending on the load.
- ❖ Only "H" type is applicable. Please use "H" type motor.