

PM-67 DC-MOTOR CONTROLLER 24V 3A



FEATURES:

- Direction change
- Braking
- Continuous / 2-step speed control
- Adjustable acceleration / braking ramp
- Adjustable current limit
- Adjustable load compensation
- Supply voltage variation compensated
- High efficiency
- Self recovery fuse
- Rail mountable

EM-67 DC-motor controller is designed for 24V permanent magnet motors with brushes in the power range of 5-70W (0,2-3A). Due to advanced PWM-controlling the unit runs with high efficiency and low thermal loss. The braking energy is fed to a power resistor.

The output voltage of the unit is regulated so that changes in supply voltage won't affect the motor speed. Additionally the unit has RI-compensation, that can be used to minimize motor speed changes in changing loading situations.

The required amount of RI-compensation depends on the motor used and is set with a trim. With this feature, a good motor speed versus control voltage ratio can be reached. Speed adjustment can be made with potentiometer or voltage signal. Alternatively the unit can also be used in two speed mode. In this case the speeds are set with trimmers on the card, and activation is done with switch or control voltage. The unit gives additional 10V for potentiometer and control switches.

Acceleration / braking ramp can be adjusted depending on the situation, this feature gives controlled and smooth direction change. Direction change can be controlled with either switch or control voltage. The supply inputs protected against overcurrent and reversed polarity using a self recovery fuse. EM-67 is EMC-tested and meets heavy industry standards.

TECHNICAL DATA:

Supply	20...34 Vdc
Idle current	approx. 40mA
Control voltage	0...5V / 0...10V
Control current	3A rms / 5A mom
Control power	70W rms
Braking power	30W (1/10 duty cycle)
Voltage loss	1V @ $I_m=3A$
Current limit	0.2...5A
Fuse	3A self recovery
Ramp	0.5...10s
Control potentiometer	1...10kohm
Digital control	"on" @ $U_{in}=4...30V$ "off" @ $U_{in}=0...1V$ or open
EMC-testing	EN 50081-2 & 50082-2
Dimensions	65x72x30mm
Weight	approx. 70g

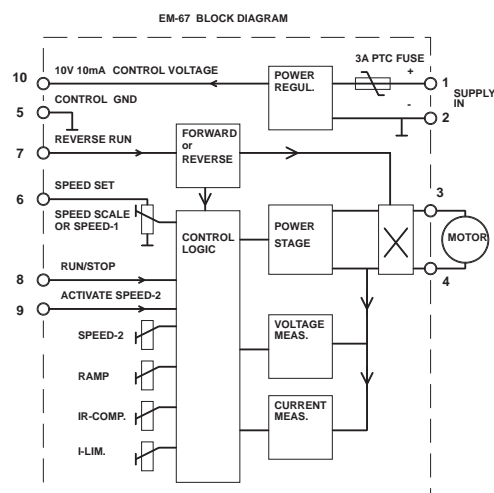

EM-67 OPERATING AND CONNECTION INSTRUCTIONS

Supply voltage must be DC-voltage 20...34V (recommended 26...32V) with less than 20% ripple. At first set all trims to the middle position, except P5 in the minimum position.

ADJUSTMENTS

P1 RAMP

Use trim to set acceleration and braking ramp. Adjustment range is 0.5...10s.

P2 SPEED SET FOR SPEED2

Use trim to change the preset value of speed2. Adjustment range is 0...100%.

P3 CURRENT LIMIT

Use trim to set the maximum current of the motor. A red light indicates the activation of the current limit. Adjustment range is 0.2...5A

P4 CONTROL RANGE

Use trim to set the desired control range. The minimum range is 0...5V and maximum 0...50V. Also used for speed1 without potentiometer.

P5 LOAD COMPENSATION (RI)

Use trim to compensate the load affecting the motor speed. Compensation level can be increased until the motor starts to twitch. Set the initial value to the minimum.

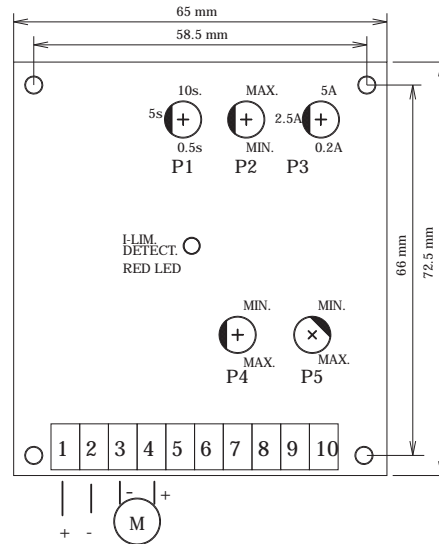

1. Supply 20-34Vdc
2. Supply GND 0V
3. Motor (-)
4. Motor (+)
5. Control GND 0V
6. Speed control input
7. Direction change +run
8. Run / Stop.
9. Switch preset speed2
10. Additional voltage 10V 10mA

Direction change can be added to following examples if needed. Note that direction change also starts the motor.

Direction change using control voltage. Can be used with other examples if needed.

Speed set using potentiometer. Scale range with trim P4.

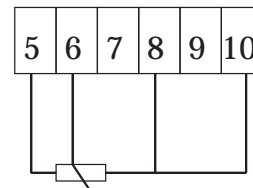
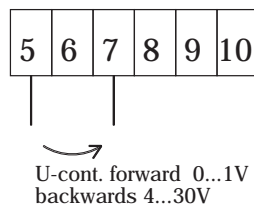
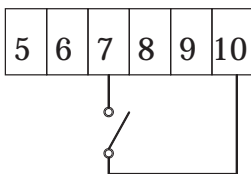

Speed set using potentiometer, activation using run/stop switch.

Speed set using voltage signal.

Two speed mode. Speeds are set using trims P2 (pin9) and P4 (pin6). Activation using switches.

