

Stepper motor | 20 mm 2 Phase hybrid stepper motor

Step Angle	----	1.8°
Step Angle Accuracy	----	± 5% (full step, no load)
Resistance Accuracy	----	± 10%
Inductance Accuracy	----	± 20%
Insulation Resistance	----	500VDC 100MΩMin
Dielectric Strength	----	500VAC 1 minute
Ambient Temperature	----	-20°C-- +50°C
Temperature Rise	----	80°C Max (rated current)
Shaft Axial Play	----	0.08mm Max (450g load)
Shaft Radial Play	----	0.02mm Max (450g load)
Max Axial Force	----	10N
Max Radial Force	----	28N (20mm from the flange)
Insulation Class	----	B

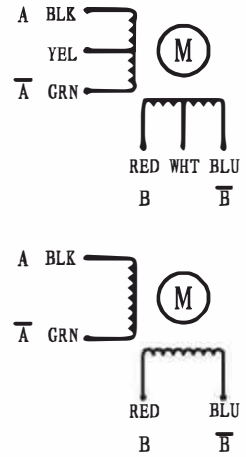

* Specifications

Model	Motor Codes	Voltage /Phase	Current /Phase	Resistance /Phase	Inductance /Phase	Holding Torque	NO. of Leads	Rotor Inertia	Weight	Length
Units		V	A	Ω	mH	g. cm		g. cm ²	Kg	mm
SY20STH30-0604A	010030000	3.9	0.6	6.5	1.7	180	4	2	0.06	30
SY20STH33-0604A	010032000	3.9	0.6	6.5	1.7	180	4	2	0.06	33
SY20STH42-0804A	010042000	4.32	0.8	5.4	1.5	300	4	2	0.08	42

* Dimension

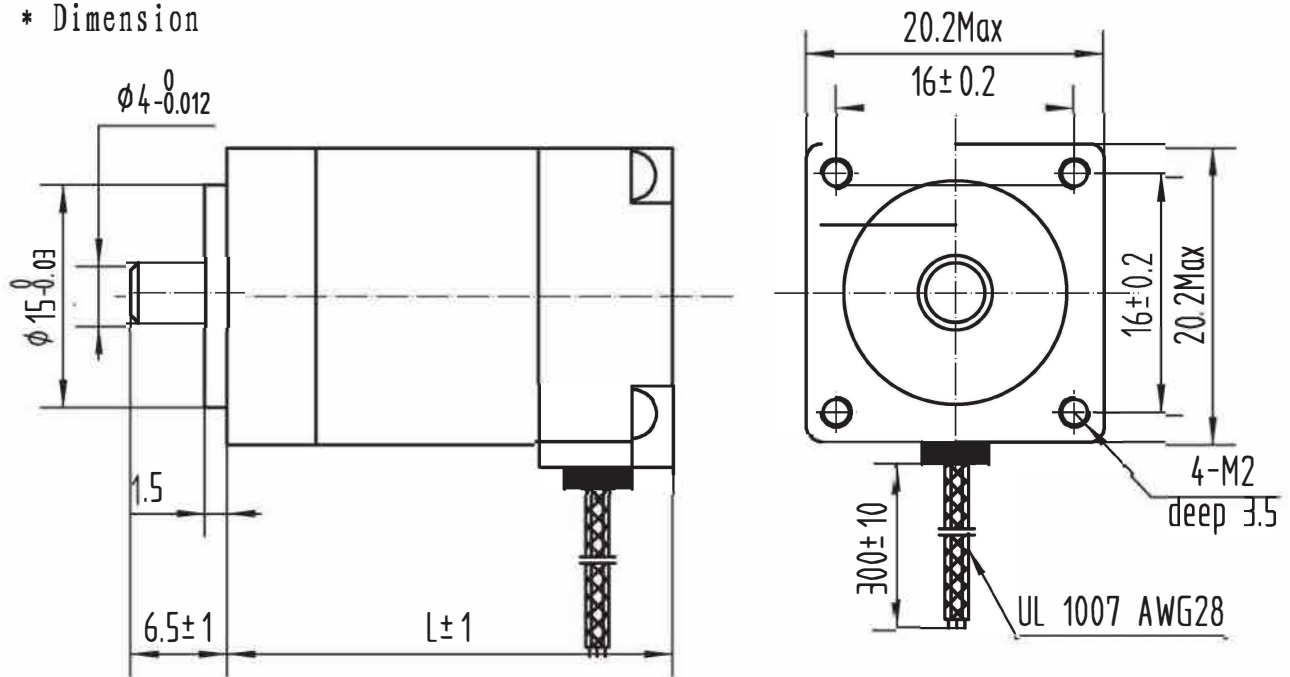

Stepper motor | 20 mm 2 Phase hybrid stepper motor

- Pull out torque curve:

