

Powermec

SPECIFICATIONS

Title	Combi type	XFA630-□	XFA850-□	XFA9100-□
	Gear type	XFM630G	XFM850G	XFM9100G
	D-Cut type	XFM630D	XFM850D	XFM9100D
Rated Output (continuous) W		30	50	100
Power Input	Voltage V	DC24V		
	Rated Input Current A	2.1	3.1	6.2
	Maximum Input Current A	3.7	5.4	9.8
Rated Torque N·m(kgf·cm) (lb·in)		0.12(1.2) (1.06)	0.2(2.0) (1.77)	0.4(4.0) (3.54)
Starting Torque N·m(kgf·cm) (lb·in)		0.15(1.5) (1.33)	0.24(2.4) (2.12)	0.5(5.0) (4.43)
Motor Permissible Load Inertia J kg·m ² (oz·in ²)		1.8x10 ⁻⁴ (9.84)	3.3x10 ⁻⁴ (18.04)	5.6x10 ⁻⁴ (30.62)
Rated Speed r/min		2,500		
Speed Control Range r/min		200~3,000 (Speed Ratio 1:15)		
Speed Regulation	Load	Less than ±0.5% (0 ~ rated torque, Rated Speed, rated voltage, normal temperature)		
	Voltage	Less than ±0.5% (supply voltage ±10%, Rated Speed, no load, normal temperature)		
	Temperature	Less than ±0.5% (0~+50°C, Rated Speed, no load, rated voltage)		

※ Start-up torque should be applied for within 5sec at 2,000r/min or lower rpm.

※ □ of item name represents the reduction ratio.



Powermec

COMMONALITIES

Category	Specifications
SLOW RUN / SLOW STOP	0,5 to 10 seconds (Applicable for both Slow Run and Slow Stop, Setting without load)
Speed Control Method	1. Built-in Potentiometer 2. External Potentiometer (20K Ω 1/4W) 3. External DC Voltage(0~5 Volt)
Input Signal	C-MOS negative logic inputting method.
Output Signal	Opencollector output, external use conditions: Less than 26.4V 10mA, common for Speed Out and Alarm Out.
Protection Functions	When below-shown protection function works, an alarm signal of the driver is generated and the motor is automatically stopped. <ul style="list-style-type: none"> ● Protection for machine overload : When an overload that exceeds the motor's rate torque has been continued for more than 5 seconds ● Protection for overvoltage : When the voltage permitted for the control unit has exceed specified voltage ● Protection guard for image formation : When malfunction occurs in the motor feedback signals due to cables disconnection and connector disconnection. ● Low-voltage protection function : Case that the voltage applied to the driver is lower than DC24V by about 25% ● Protection for over speeding : When the speed of the motor exceed 3500r/min ● Over-voltage protection function : Case that the voltage applied to the driver is higher than DC24V by 15% or more
Maximum extension distance	When using an extension cable is used between the motor and driver
Rating	Continuous

GENERAL SPECIFICATIONS

Item	Motor	Control Unit
Dielectric Strength	If applying 60Hz 500V between the coil and the case for 1 minute after continuous operating under normal temperature and humidity conditions, any fault is not occurred.	No problem is found when 50/60Hz 500V is applied between power input and radiator plate after continuous operation at normal temperature and normal humidity.
Insulation Resistance	After continuous operating under normal temperature and humidity conditions, if measured the resistance value between the coil and the case using DC500V Mega Tester, should be over 100M Ω .	If the resistance value between protection ground terminal and power input is measured using DC500V Mega Tester, should be over 100M Ω .
Ambient Temperature	0°C to +40°C(+32°F to +104°F) (nonfreezing)	0°C to +50°C(+32°F to +122°F) (nonfreezing)
Ambient Humidity	Less than 85% (non condensing)	
Atmosphere	No corrosive gas or dust.	
Insulation grade	Class B (130°C)	
Degree of Protection	IP65 (excluding the output shaft side)	IP00

Caution) Use it, ensuring that surface temperature of motor does not exceed over 90°C.

PERMISSIBLE TORQUE – GEARED MOTOR

		N·m/kgf·cm)(lb·in)								
MODEL	REDUCTION RATIO	5	10	15	20	30	50	100	200	
		MOTOR SPEED	200~2500r/min	40~500	20~250	13.4~167	10~125	6.6~83	4~50	2~25
		3000r/min	600	300	200	150	100	60	30	15
XFM630-□	200~2500r/min λ	0.54 5.51(4.78)	1.1 11.22(9.74)	1.6 16.32(14.16)	2.2 22.43(19.47)	3.1 31.61(27.44)	5.2 53.0(46.02)	6 61.18(53.10)	6 61.18(53.10)	
	3000r/min λ	0.27 2.75(2.39)	0.54 5.51(4.78)	0.81 8.26(7.17)	1.1 11.22(9.74)	1.5 15.30(13.28)	2.6 26.51(23.01)	5.2 53.03(46.02)	6 61.18(53.10)	
XFM850-□	200~2500r/min λ	0.9 9.18(7.97)	1.8 18.35(15.93)	2.7 27.53(23.90)	3.6 36.71(31.86)	5.2 53.03(46.02)	8.6 87.7(76.12)	16 163.15(141.61)	16 163.15(141.61)	
	3000r/min λ	0.45 4.59(3.98)	0.9 9.18(7.97)	1.4 14.3(12.39)	1.8 18.4(15.93)	2.6 26.51(23.01)	4.3 43.85(38.06)	8.6 87.7(76.12)	16 163.15(141.61)	
XFM9100-□	200~2500r/min λ	1.8 18.35(15.93)	3.6 36.71(31.86)	5.4 55.06(47.79)	7.2 73.42(63.73)	10.3 105.03(91.16)	17.2 175.39(152.23)	30 305.91(265.52)	30 305.91(265.52)	
	3000r/min λ	0.9 9.18(7.97)	1.8 18.35(15.93)	2.7 27.53(23.90)	3.6 36.71(31.86)	5.2 53.03(46.02)	8.6 87.7(76.12)	17.2 175.39(152.23)	30 305.91(265.52)	

※ □ of item name represents the reduction ratio.

※ Rotation direction is the same direction of additional motor marked in the □, others is reverse direction.



Powermec

PERMISSIBLE LOAD INERTIA (J)-GEARED MOTOR

 $J \times 10^{-4} \text{ kgf-m}^2 (\text{GD}^2 \text{ kgf-cm}^2)$

Model	Gear Ratio	5	10	15	20	30	50	100	200
XFA630-□K		1.55 (6.2)	6.2 (24.8)	14 (56.0)	24.8 (99.2)	55.8 (223.2)	155 (620.0)	155 (620.0)	155 (620.0)
XFA850-□K		5.5 (22.5)	22 (88.0)	49.5 (198.0)	88 (352.0)	198 (792.0)	550 (2200)	550 (2200)	550 (2200)
XFA9100-□K		25 (100.0)	100 (400.0)	225 (900.0)	400 (1600)	900 (3600)	2500 (10000)	2500 (10000)	2500 (10000)

※ □ of item name represents the reduction ratio.

PERMISSIBLE OVERHANG LOAD AND PERMISSIBLE THRUST LOAD

Model	Gear Ratio	Permissible Overhang Load				Permissible Thrust Load		
		10mm(0.3937 in) from end of the output shaft.		20mm(0.7874 in) from end of the output shaft.		N	kgf	
		N	kgf	N	kgf			
Geared Motor	XFA630-□K	5	100	10	150	15	40	4
		10~20	150	15	200	20		
		30~200	200	20	300	30		
	XFA850-□K	5	200	20	250	25	100	10
		10~20	300	30	350	35		
		30~200	450	45	550	55		
	XFA9100-□K	5	300	30	400	40	150	15
		10~20	400	40	500	50		
		30~200	500	50	650	65		
Motor	XFM630D	70	7	100	10	• Do not engage the thrust load. If unavoidable, engage below 50% of motor weight.		
	XFM850D	120	12	140	14			
	XFM9100D	160	16	170	17			

※ □ of item name represents the reduction ratio.



Powermec

GEARED MOTOR

■ Model : XFA630-□K

[Unit : mm(inch)]

- Motor : XFM630G
- Gear Head : XTG65K~XTG6200K
- Control Unit : XFD30

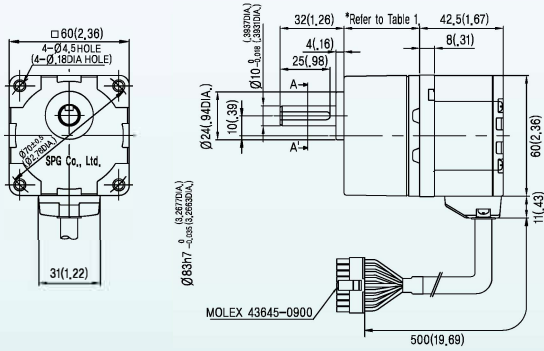

- ※ □ indicates deceleration ratio.
- ※ Gear head motor is enclosed with a bolt set.

■ Key(accessories)

■ Key Groove

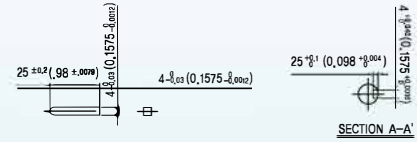

※ Table 1

Gear Ratio	Size(mm)(in)
XTG65K~XTG620K	34(1.34)
XTG630K~ XTG6100K	38(1.50)
XTG6200K	43(1.69)

MOTOR

■ Model : XFM630D

[Unit : mm(inch)]

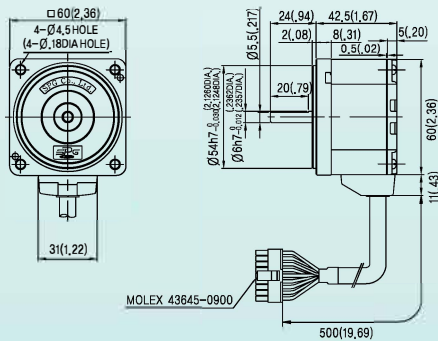

※ Table 2-Weight

Part	Weight(kg)(lbs)	
Motor	0.48(1.06)	
Gear Head	XTG65K~XTG620K	0.28(0.62)
	XTG630K~ XTG6100K	0.33(0.73)
	XTG6200K	0.37(0.82)

GEARED MOTOR

■ Model : XFA850-□K

[Unit : mm(inch)]

- Motor : XFM850G
- Gear Head : XTG85K~XTG8200K
- Control Unit : XFD50

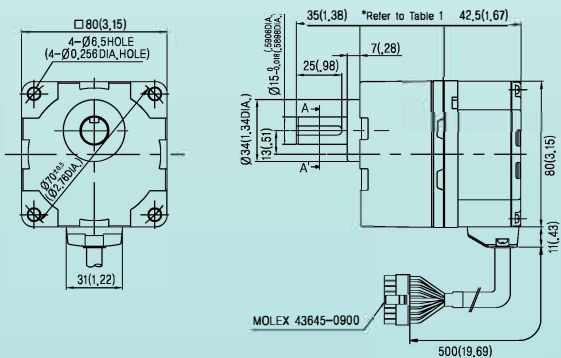

- ※ □ indicates deceleration ratio.
- ※ Gear head motor is enclosed with a bolt set.

■ Key(accessories)

■ Key Groove

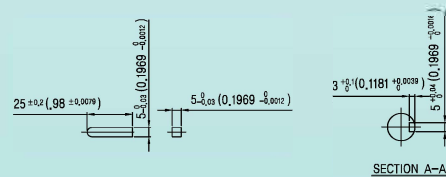

※ Table 1

Gear Ratio	Size(mm)(in)
XTG85K~XTG820K	41(1.61)
XTG830K~ XTG8100K	46(1.81)
XTG8200K	51(2.01)



Powermec

MOTOR

Model : XFM850D

[Unit : mm(inch)]

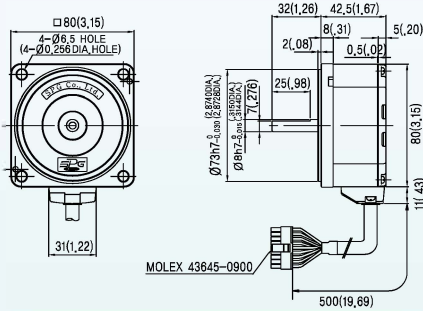

Table 2-Weight

Part		Weight(kg)(lbs)
Motor		0.75(1.65)
Gear Head	XTG85K~XTG820K	0.61(1.34)
	XTG830K~ XTG8100K	0.72(1.59)
	XTG8200K	0.80(1.76)

GEARED MOTOR

Model : XFA9100-□K

[Unit : mm(inch)]

- Motor : XFM9100G
- Gear Head : XTG95K~XTG9200K
- Control Unit : XFD100

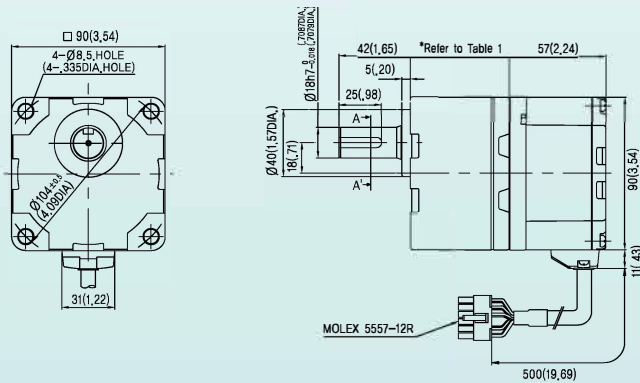

Key(accessories) Key Groove

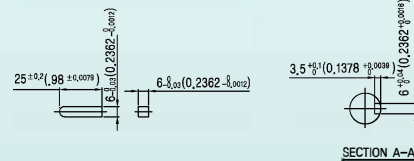

Table 1

Gear Ratio	Size(mm)(in)
XTG95K~XTG920K	45(1.77)
XTG930K~ XTG9100K	58(2.28)
XTG9200K	64(2.52)

- indicates deceleration ratio.
- ※ Gear head motor is enclosed with a bolt set.

MOTOR

Model : XFM9100D

[Unit : mm(inch)]

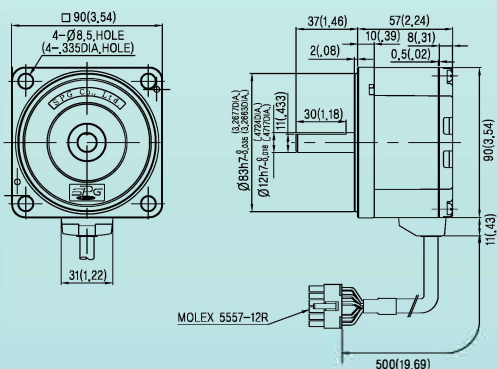

Table 2-Weight

Part		Weight(kg)(lbs)
Motor		1.34(2.95)
Gear Head	XTG95K~XTG920K	0.85(1.87)
	XTG930K~ XTG9100K	1.15(2.54)
	XTG9200K	1.30(2.87)



Powermec

DRIVER

■ Model : XFD30, XFD50 (Weight : 0.1kg)

[Unit : mm(inch)]

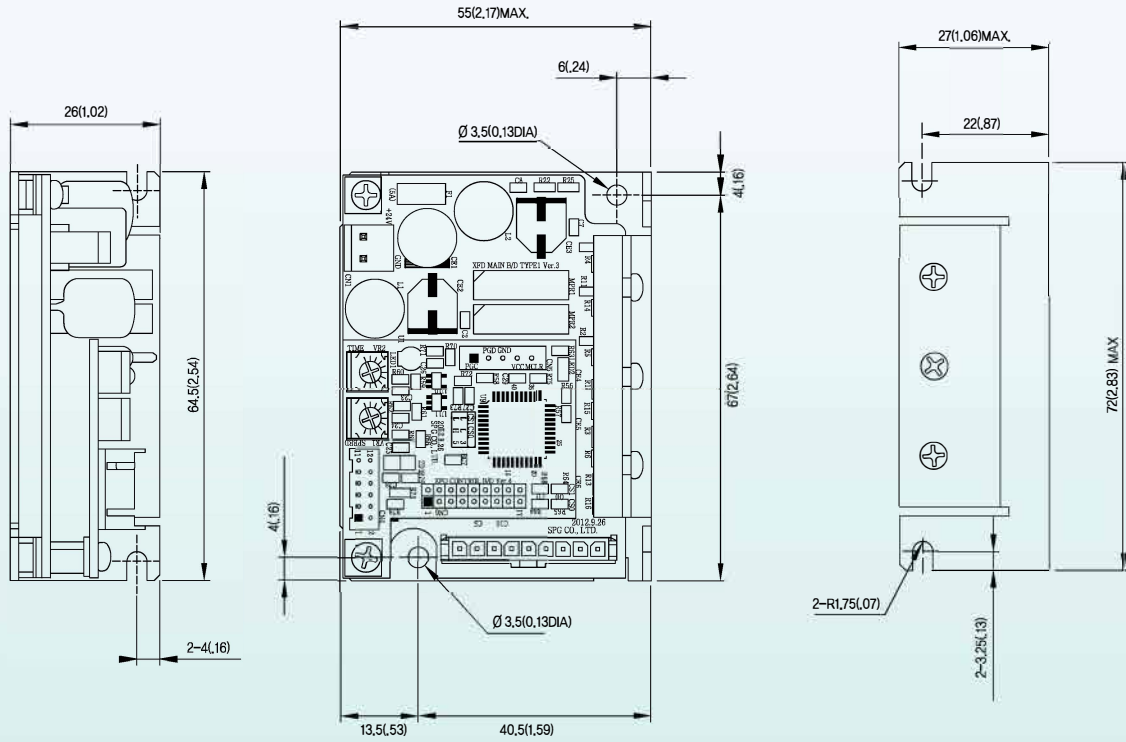

■ Model : XFD100 (Weight : 0.3kg)

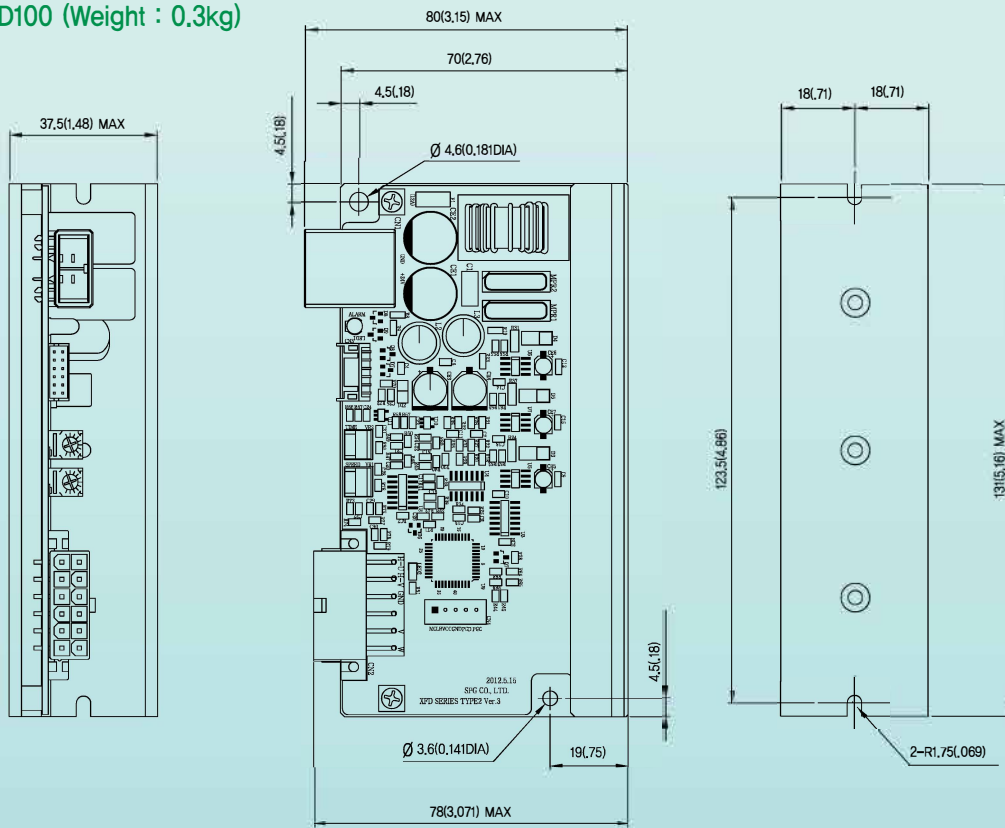

Powermec

CONTROL UNIT

- Assembled bolt is attached to gear head or geared motor.

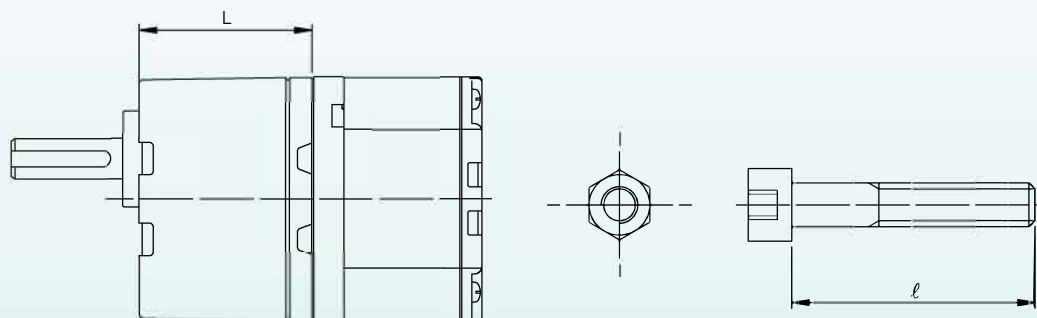

Model	Accessory Bolts (Flat W/S, Spring W/S, hexagonal nut×4)		
	L(mm)(in)	l (mm)(in)	Bolt Names
XTG65K~XTG620K	34(1.34)	50(1.97)	M4 P0.7
XTG630K~ XTG6100K	38(1.50)	55(2.17)	
XTG6200K	43(1.69)	60(2.36)	
XTG85K~XTG820K	41(1.61)	65(2.56)	M6 P1.0
XTG830K~XTG8100K	46(1.81)	70(2.76)	
XTG8200K	51(2.01)	75(2.95)	
XTG95K~XTG920K	45(1.77)	75(2.95)	M8 P1.25
XTG930K~XTG9100K	58(2.29)	90(3.54)	
XTG9200K	64(2.52)	95(3.74)	

Powermec

XFU630G/XFU630D

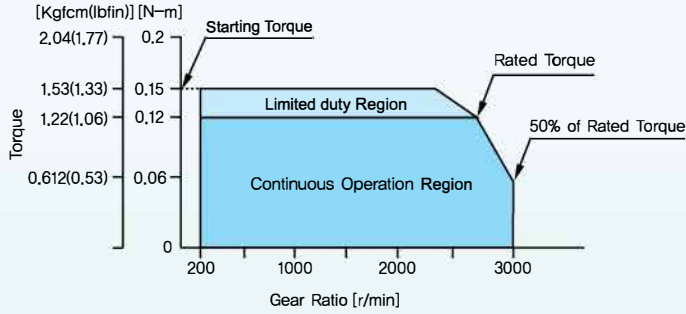

✘ This is the case that the cable is not extended at DC24V.

XFU850G/XFU850D

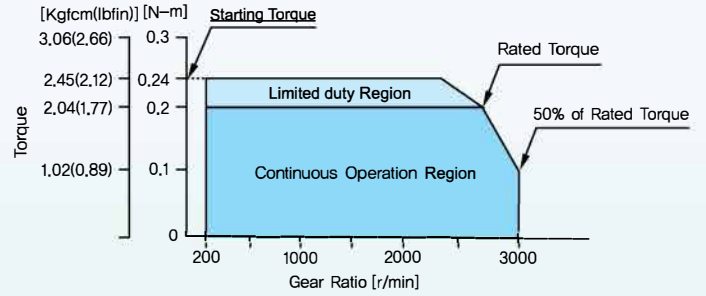

✘ This is the case that the cable is not extended at DC24V.

XFU9100G/XFU9100D

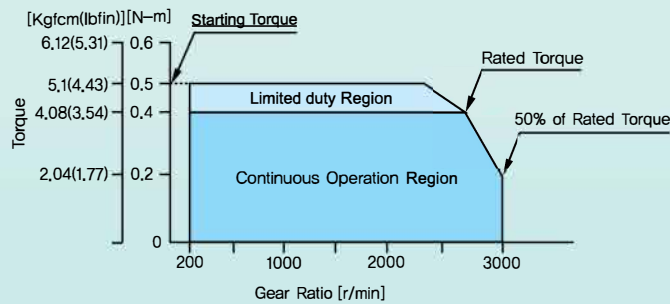

✘ This is the case that the cable is not extended at DC24V.



Powermec

Name and function of each part

DRIVER NAME : XFD30, XFD50

**Acceleration
Deceleration time controller**

The acceleration time after start of the motor and the deceleration for stop of the motor can be set. At shipment, such time is set as the shortest time.

Power connector (CN1)

Power cable is connected.

Internal speed controller

The operation speed of the motor can be set. At shipment, it is set as 0 r/min.

Radiation plate

Grooves for installation (two)

Motor connector (CN2)

Motor cable is connected.

In/Out signal connector (CN4)

In/Out cables are connected with external controllers such as programmable controller.

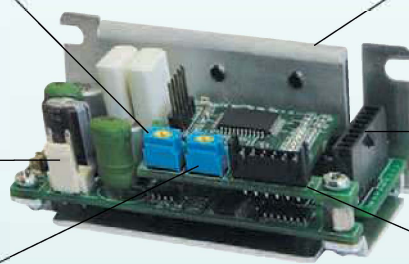

DRIVER NAME : XFD100

Power connector (CN1)

Power cable is connected.

In/Out signal connector (CN3)

In/Out cables are connected with external controllers such as programmable controller.

**Acceleration
Deceleration time controller**

The acceleration time after start of the motor and the deceleration for stop of the motor can be set. At shipment, such time is set as the shortest time.

Radiation plate

Grooves for installation (two)

Grooves for installation (two)

Motor connector (CN2)

Motor cable is connected.

Internal speed controller

The operation speed of the motor can be set. At shipment, it is set as 0 r/min.

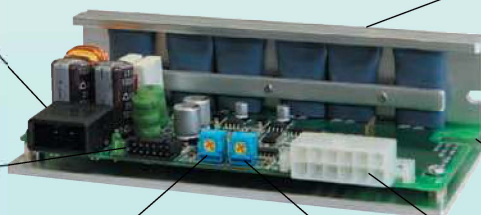

Powermec

INTERFACE DIAGRAM

■ DRIVER NAME : XFD30, XFD50

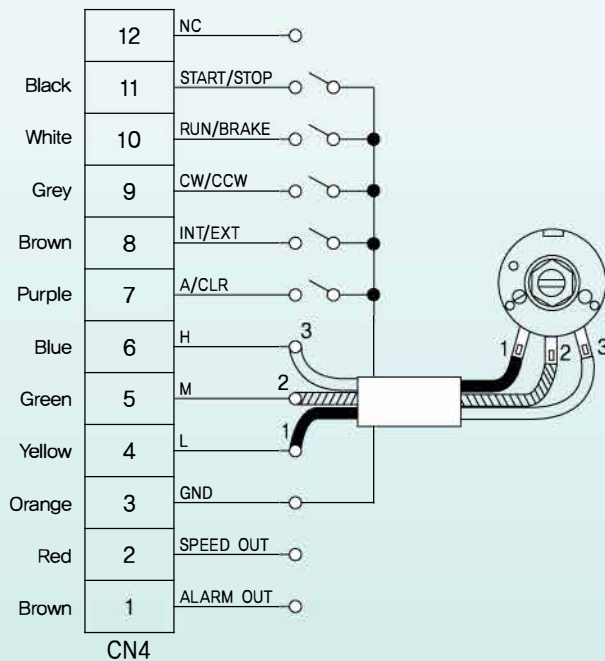
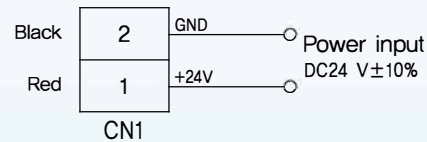

* For setting the speed at the outside, a speed controller (optional) or DC power should be connected.

■ DRIVER NAME : XFD100

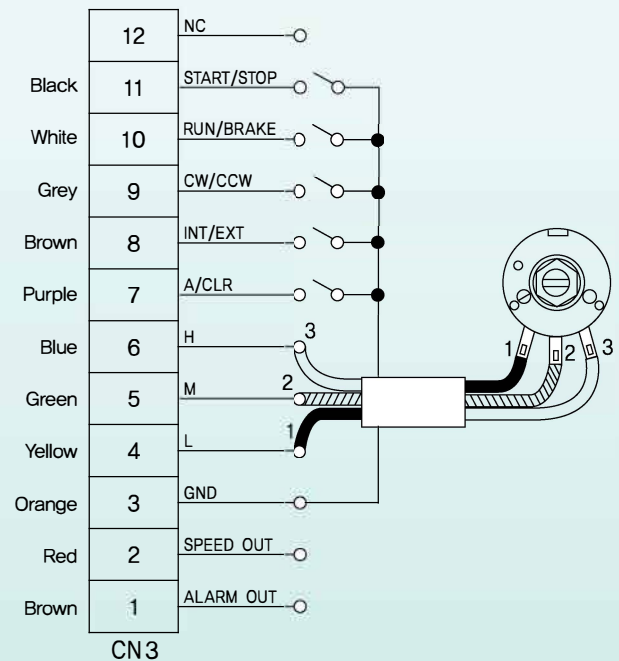
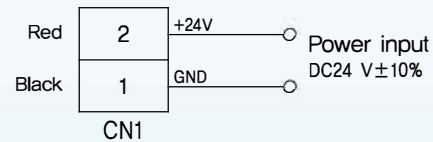

* For setting the speed at the outside, a speed controller (optional) or DC power should be connected.

Note

- Input/Output signal cables should be extended within 2m and should be done as short as possible in order to suppress the influence of noise.
- Input/Output signal cables shall be arranged apart from induction load such as electronic relay by 200mm at least and power cable and motor cable should be arranged cross rather than parallel.
- The connectors of input/output signal cables and the cables which are at the opposite side and are not used should be insulated, should be connected with external controllers to meet the purpose of signals, or should be connected with signal GND.



Powermec

Operation

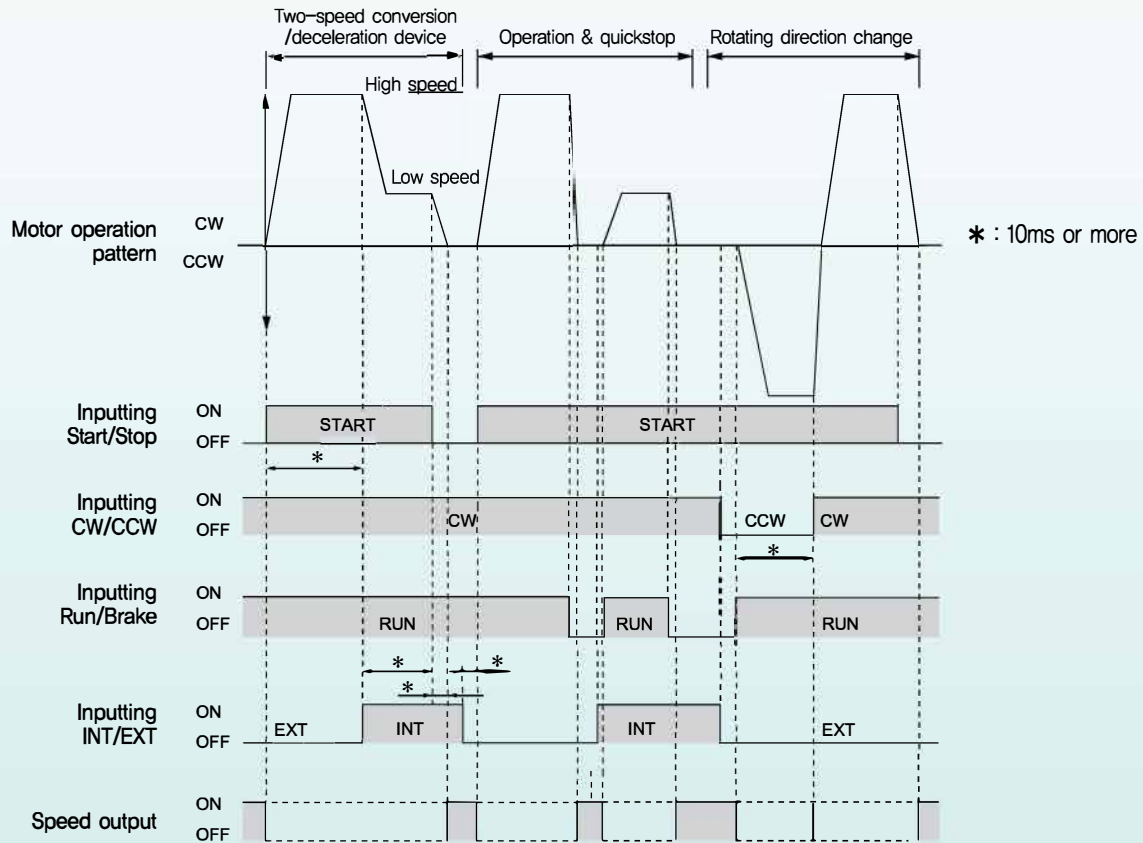

Inputting Start/Stop

At On position (L Level), Start is selected and the motor is operated.

At Off position (H Level), Stop is selected and the motor stops (Quickstop function is not available).

Inputting Run/Brake

At On position (L Level), Run is selected and the motor is operated.

At Off position (H Level), Brake is selected and the motor is quickly stopped.

Setting Acceleration/Deceleration time

Acceleration time and deceleration time is set as the same. The controller should be adjusted using an insulated driver. Clockwise rotation increases the time. The time may be set within 0.5–10sec of range. At shipment, the time is set as the shortest time.

Acceleration time means the time to be taken by the motor to reach rated rotation speed from stopped state.

Deceleration time means the time to be taken by the motor to stop from rated rotation speed.

Actual acceleration/deceleration time is influenced by the customer's condition of use, inertia of load, and torque of load, etc.

Note

- If both Start/Stop and Run/Brake are at Off positions (H Level), Brake has precedence.
- Do not input (i.e. On/Off change) Start/Stop, Run/Brake, and CW/CCW or INT/EXT at the same time. Each input operation requires at least 10msec of interval.
- Operation is done at the acceleration/deceleration time which is set using a controller.



Powermec

Signal input circuit

- The signals of the driver is inputted as C-MOS input. The status of the signals is [ON : 0~0.5 V(L Level)] or [OFF : 4~5 V(H Level)].

(1) Input circuit

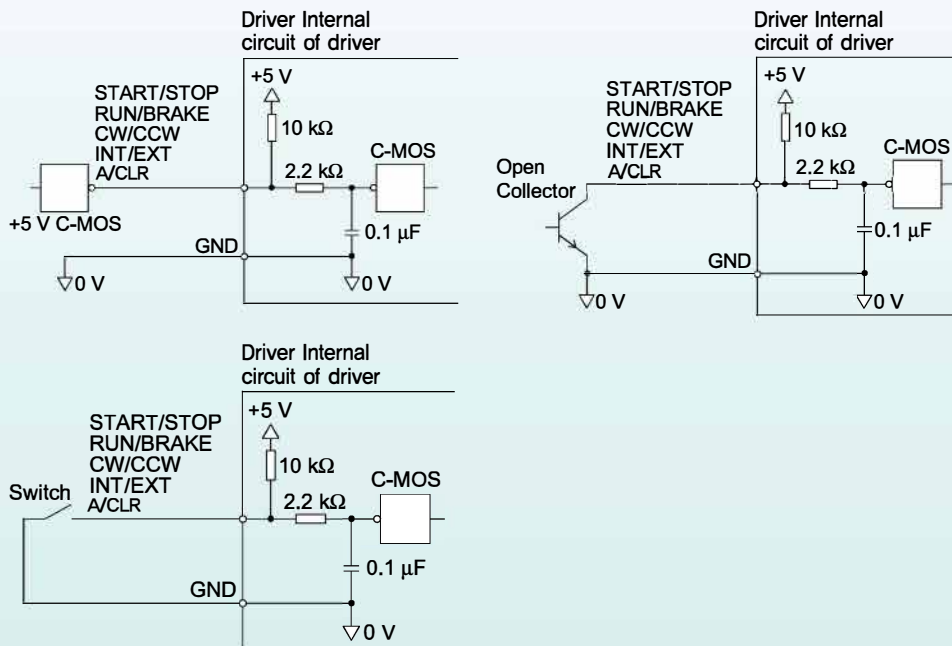

Inputting Start/Stop & Inputting Run/Brake

For operation and quickstop (or stop) of the motor, these two kinds of signals are used.

	Inputting signals		
Inputting Start/Stop	ON(L Level)	ON(L Level)	OFF(H Level)
Inputting Run/Brake	ON(L Level)	OFF(H Level)	ON(L Level)
Status of motor	Operation*1	Quickstop	Stop*2

*1 The motor is rotated at the speed which is set by selecting internal speed controller, external speed controller, or external DC power.
The motor is accelerated at the time which is set using Slow Run/Slow Stop time controller.

*2 The motor is decelerated at the time which is set using Slow Run/Slow Stop time controller.

Powermec

Signal generation circuit

- The signals of the driver are the signals of Transistor Open Collector. The state of the signal is [On: current on] or [Off: current off] of the internal transistor rather than the voltage level of the signal.

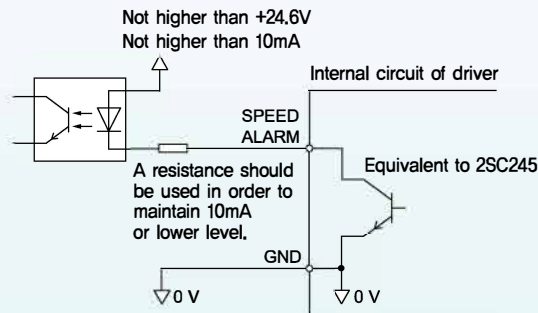

ALARM OUT

In the case shown below, driver protection function is actuated, Alarm Out is turned off (H Level), and the motor stops. In this case, LED flashes or lights; check the content of protection function.

※ LED is momentarily lighted when power is applied; this is not abnormal phenomenon.

- The number of LED flashing indicates the content of actuated protection function.

※ Case that protection function against overload is actuated.

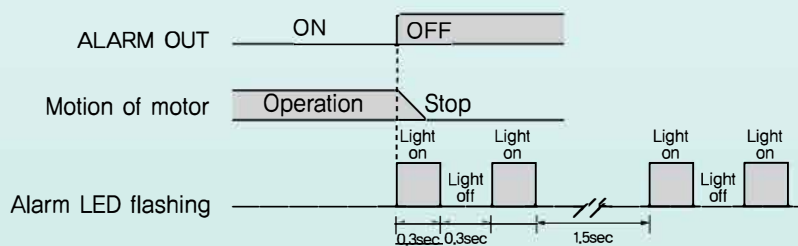

Protection function	ALARM LED flashing number	Cause
Protection against overload	Two times	The load exceeding the rating load of the motor is applied for 5sec or longer.
Protection against open phase	Three times	Abnormal motor feedback signal is generated due to disconnection of motor cable or poor contact of connector.
Protection against over-voltage	Four times	The voltage applied to the driver is higher than DC24V by 15% or more
Protection against low-voltage	Five times	The voltage applied to the driver is lower than DC24V by 25% or more
Protection against over-speed	Six times	The motor speed exceeded 3,500r/min.

Alarm Out is at On position (L Level) if the driver is normal and is at Off position (H Level) in case of Alarm. When Alarm Out is at Off position (H Level) and when the motor stops, remove the cause of actuation of the protection function referring to the flashing cycle of LED. When safety is secured by removing the cause, reset the Alarm.

Note

- If Alarm Out is at Off position (H Level), put Start/Stop and Run/Brake at Off positions (H Level).

Powermec

■ SPEED OUT

12/15 pulse signal is generated per revolution of motor shaft synchronized with motor operation.
The rotating speed of the motor may be calculated by measuring output frequency of Speed Out.

$$\text{Output frequency of Speed Out [Hz]} = \frac{1}{T}$$

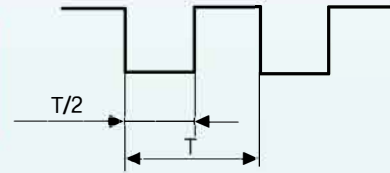

■ If 30W,

$$\text{Motor rotating speed [r/min]} = \frac{\text{Output frequency of Speed Out [Hz]} \times 60}{12}$$

■ If 50W/100W,

$$\text{Motor rotating speed [r/min]} = \frac{\text{Output frequency of Speed Out [Hz]} \times 60}{15}$$

For displaying the rotating speed of motor shaft or decelerator shaft
Use a digital speed indicator [SID250] (after purchasing).

Note

- The input/output signal cables should be extended within 2m.
- The input/output signal cables should be arranged with separation from power cable and motor cable.



Powermec

How to set the speed

The rotating speed of the motor may be set using the attached external speed controller or external DC power as well as internal speed controller. The speed setting range is 200–3000 r/min. The rotating speed may be set in two kinds by combining internal speed controller with external speed controller or by combining internal speed controller with external DC power. (Where, rated rotation speed is 2,500r/min.)

■ When using the internal speed controller

Adjust the speed using a minute driver. Clockwise rotation elevates the speed.
(At shipment, it is set as 0 r/min.)

■ When using an external speed controller

By connecting an external speed controller with the driver terminal rack, the speed may be changed within the range of 200–3000r/min. Anticlockwise rotation of speed controller stops it.

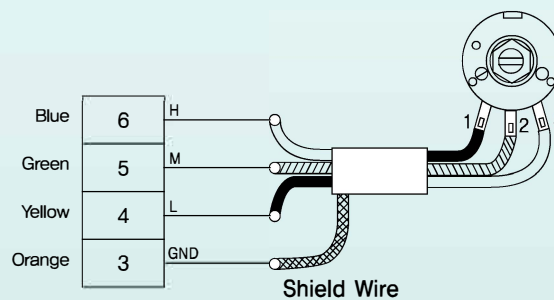
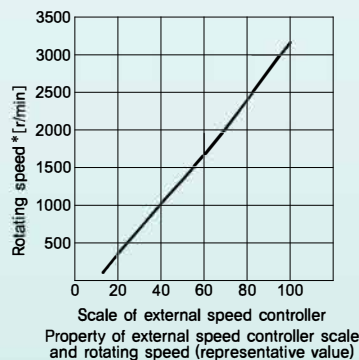

■ When using external DC power

The motor speed may be changed in the range of 200–3,000r/min using 0–5V of external DC power.
At 0V of DC power, the motor stops (Prepare the power having at least 1mA of current capacity).

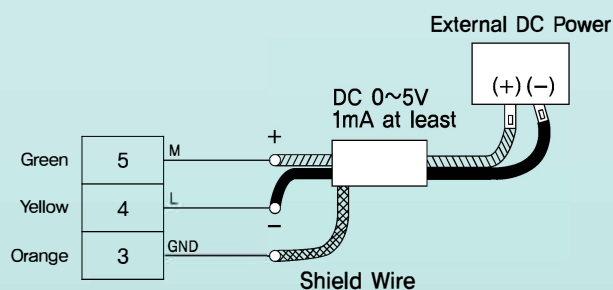
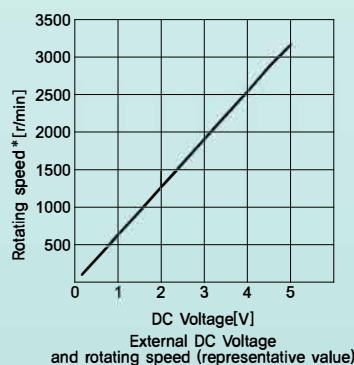

Note

- 5V or lower external DC power should be used. If not, the driver may be damaged.
- External DC power should be connected in consideration of the polarities. If not, the driver may be damaged.
- If external DC power is connected using shield cables, connect it near the connector of input/output cables and connect the shield cable using Pin No.3 GND.

Powermec

Parallel operation

When two or more motors are operated at the same speed, external DC power or external speed controller may be used.

■ When using an external speed controller

- 1) Parallel operation means that a plurality of motors are operated at the same rotation speed using an external speed controller. As shown in the figure below, the speed is set at VRx using common power line and speed control line.
- 2) The resistance of the external speed controller may be obtained as follows.

When N sets of drivers are used, resistance VRx $VRx=20/N$ [K Ω], $N/4$ [W]
 Ex) If two sets of drivers are used, 10K Ω , 1/2W.

- 3) For other input/output signals, connection should be done for each driver.
- 4) The difference in the speeds of the motors may be adjusted by connecting the Terminal M of Driver #1 with 1.5K Ω and 1/4W of resistance and by connecting the terminals of M's of other drivers with 5K Ω and 1/4W of variable register (ADJ).
- 5) Parallel operation using an external speed controller should be limited within 5 sets.

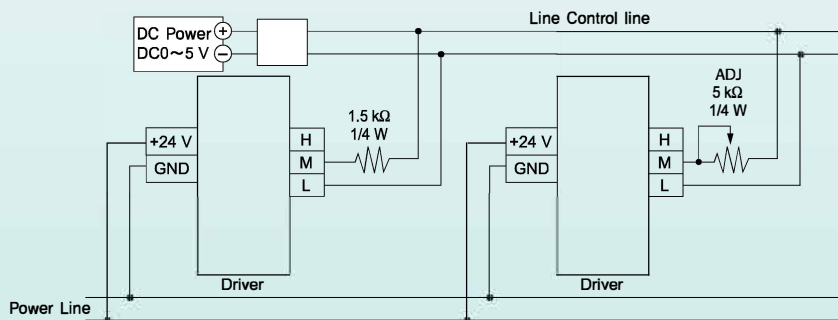

■ When using external DC power

- 1) DC power should have the DC capacity shown below, at least.

When N sets of drivers are used, DC capacity $I=1 \times N$ [mA]
 Ex) If two sets of drivers are used, 2mA, at least.

- 2) For other input/output signals, connection should be done for each driver.
- 3) The difference in the speeds of the motors may be adjusted by connecting the Terminal M of Driver #1 with 1.5K Ω and 1/4W of resistance and by connecting the terminals of M's of other drivers with 5K Ω and 1/4W of variable register (ADJ).

