

EM-136 STEPPER MOTOR MICROSTEPPING CONTROLLER UNIT 12-45V 0.5-4A



FEATURES:

- Bipolar chopper
- Wide supply voltage range
- Full-, half-, quarter-, and 1/8-step operation
- 8-programmable phase currents
- Auxiliary oscillator
- Acceleration- and braking ramp
- Self recovery fuse
- Very high efficiency
- Low heat dissipation
- Rail mounting base available

EM-136 is bipolar-chopper type stepper motor controller. Bipolar operation suits most stepper motors and provides the best torque. The microstepping feature gives high performance also at low rpm. The power stage is mosfet-type so it runs with very high efficiency.

There are four stepping modes: full, half, quarter and 1/8. Desired mode is set with two control inputs. The phase current (current limit) can be set in eight different levels using dip-switches. A wide phase current set range makes it possible to use the device with several different motors.

The controller features an auxiliary oscillator, which has 7 preprogrammed frequencies. The frequency is set with three control inputs. Auxiliary oscillator in EM-136 has also an acceleration ramp feature, which can be used to change frequencies flexibly, so that the motor will start up reliably even at high frequencies. The acceleration ramp time is set with a trim.

The inputs operate with so called positive logic, in other words the inputs are activated with connecting the input to positive voltage. The inputs also work with TTL-logic level control.

The power state of EM-136 has self recovery fuse that protects the controller from over current and reversed input voltage polarity.

TECHNICAL DATA:

Operating voltage	12-45Vdc
Idle current	approx. 25mA (enable "0")
Current set	0.5; 1.0; 1.5; 2.0; 2.5; 3.0; 3.5 and 4.0A
Voltage loss	1V when $I_m=1A$
Fuse	4A self recovery.
Aux. osc. freq.	200, 500, 1000, 2000 Hz 3000, 5000, 8000 Hz
Ramp speed	0,2...3s (0...8000 Hz)
Aux. freq. precision	better than 0,5%
Digital control	"on" when U_{in} 4 -30V "off" when U_{in} 0-1V
Step freq.	max. 15 kHz
Operating temp.	0-50°C
Dimensions	87x73x35mm
Weight	approx. 90g

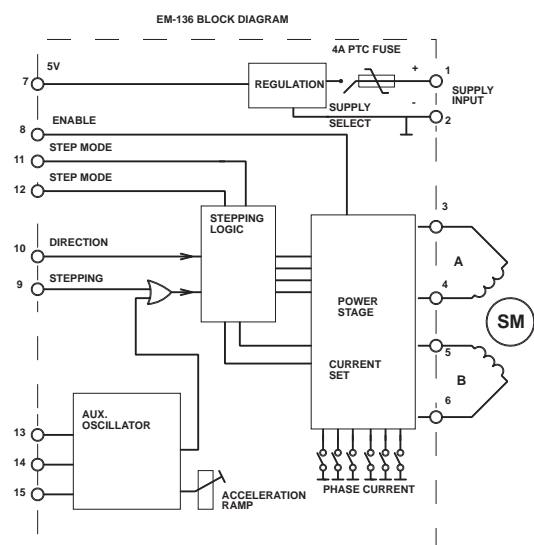

EM-136 WIRING AND INSTALLATION

Supply voltage 12-45Vdc, ripple less than 20%
 Make sure that the current feed capability of the voltage source is adequate for the application.
 The undervoltage situation can cause undesired effects for the function.

The phase current is set with PHASE CURRENT switch (see the table below). Notice that the motor do not always need the nominal phase current. Often the motor works better with lower than the nominal current. Find the best current for your application, but do not exceed the nominal current of the motor.

Control inputs are activated using switches or voltage signal. Driver has a positive control logic
 5...30V = "on" , 0-1V or OPEN = "off"

There are four stepping modes : full, half, 1/4 and 1/8. The full-step is good for higher speeds. The 1/8-step gives best resolution on positioning use, and also the smoothest run on low speeds. Stepping mode is selected with STEP MODE inputs A & B (look at table below).

If used with external stepping frequency source, connect frequency signal to STEP PULSE input. Incoming pulse level should be 4-30V, frequency max.15kHz and minimum pulse length 25us. Internal stepping source (aux. oscillator) is set with AUX. OSC. inputs 1,2 and 3 (see the table). Aux. oscillator includes also the acceleration RAMP. It gives a smooth start towards the selected frequency. The ramp time can be adjusted from 0.2 to 3sec. The AUX. OSC. frequencies and the RAMP time are based on 20MHz crystal frequency. The crystal can be changed to be anything between 4...20MHz. The AUX. OSC. frequencies and ramp time are changed in the same proportion.

ENABLE has the highest priority.
 NOTE. If ENABLE input is "off" the output stage is turned off, (output current is off) and also the AUX. OSC is reset. So every time when the ENABLE input is turned "on" the AUX. OSC. starts with the acceleration ramp.

DIRECTION input is used to change the rotating direction. Direction change does not include the RAMP function in it self. But if it is used with the ENABLE input the ramp and the smooth direction change can be achieved.

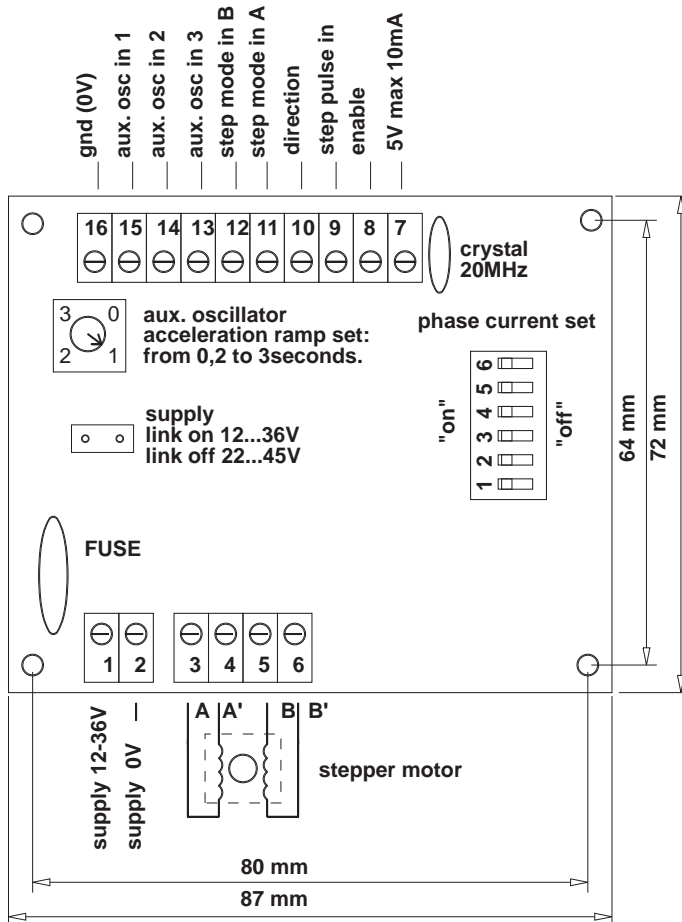

STEP MODE SET

full step: input A and B "off"
 half step: input A "on", B "off"
 1/4 step: input A "off", B "on"
 1/8 step: input A and B "on"

PHASE CURRENT SET

0.5A all "off"
 1.0A 1 and 4 "on", others "off"
 1.5A 2 and 5 "on", others "off"
 2.0A 1,2,4,5 "on", others "off"
 2.5A 3 and 6 "on", others "off"
 3.0A 1,3,4,6 "on", others "off"
 3.5A 2,3,5,6 "on", others "off"
 4.0A all "on"

AUX. OSCILLATOR FREQ. (with 20MHz crystal)

stop all aux. osc. input "off"
 200Hz in1 "on", others "off"
 500Hz in2 "on", others "off"
 1000Hz in1,2 "on", others "off"
 2000Hz in3 "on", others "off"
 3000Hz in1,3 "on", others "off"
 5000Hz in2,3 "on", others "off"
 8000Hz all aux. osc. input "on"